



**Including all PortServer TS, Digi Connect,  
and Digi One Products**

[www.digi.com](http://www.digi.com)

*Making*  
**DEVICE NETWORKING**  
*easy™*

© Digi International Inc. 2005.

Digi, Digi International, the Digi logo, the Making Device Networking Easy logo, Digi One, Digi Connect, PortServer TS, and RealPort are trademarks or registered trademarks of Digi International, Inc. in the United States and other countries worldwide. All other trademarks are the property of their respective owners.

[www.digi.com](http://www.digi.com)

*Making*  
**DEVICE NETWORKING**  
*easy*™

# Table of Contents

## Chapter 1 EIA-232 Asynchronous Interface

General EIA-232 Cable Information .....	9
Physical Cable Characteristics .....	9
Grounding Requirements.....	9
Environmental Requirements .....	9
Data Rate Information.....	9
Data Rate vs. Cable Length.....	9
Transmission Errors.....	10

## Chapter 2 EIA-232: DB-25 to DB-25

Digi DB-25 Connector Pin Assignments.....	11
DB-25 Software Handshaking (XON/XOFF) Cable .....	11
Simple Terminal/Printer Cable .....	11
DB-25 4-Wire Hardware Handshaking (DTR) Cable .....	11
Terminal/Printer Cable with DTR Handshaking .....	12
DB-25 Hardware Handshaking (RTS/CTS) Cable.....	12
Terminal/Printer Cable with RTS/CTS Handshaking .....	12
DB-25 Fully-Wired Terminal/Printer Cable .....	13
DB-25 Modem Cable .....	13

## Chapter 3 EIA-232: DB-9

Digi DB-9 Connector Options: AccelePort Xr, Xe, ClassicBoard.....	17
Fan-Out Cables .....	17
Part Numbers for DB-9 Fan-Out Cables (Standard AccelePort DB-78 Connector) .....	17
DB-9 Connector Options: Digi Neo, AccelePort Xp.....	17
Fan-Out Cables .....	17
Part Numbers for DB-9 Fan-Out Cables (Xp and Neo - 68 pin SCSI Connector) .....	17
Connector Boxes .....	18
Part Numbers for DB-9 Connector Boxes (Xp and Neo - 68 pin SCSI Connector) :	18
Part Numbers for Cable Options :	18
DB-9 Software Handshaking (XON/XOFF) Cable .....	18
Simple Terminal/Printer Cable .....	18
DB-9 4-Wire Hardware Handshaking (DTR) Cable .....	19
Terminal/Printer Cable with DTR Handshaking .....	19
Digi DB-9 Connector Pin Assignments .....	19
DB-9 Modem Cable .....	19
Fully-Wired DB-9 Terminal/Printer Cable .....	19
Terminal/Printer Cable for Software (XON/XOFF) or Hardware (RTS/CTS) Handshaking .....	20
DB-9 Hardware Handshaking (RTS/CTS) Cable.....	20
Terminal/Printer Cable with RTS/CTS Handshaking .....	20

## Chapter 4 EIA-232: RJ-45 to DB-25

Digi RJ-45 Connector Pin Assignments .....	21
RJ Connector Types.....	21
Digi RJ-45 to DB-25/DB-9 Cable Adapters.....	22
Part numbers for RJ-45 to DB-25 Cable Adapters: .....	22
Part numbers for RJ-45 to DB-9 Cable Adapters: .....	22
Digi RJ-45 to RJ-45 Cable Adapters: 8 Pin .....	22
Part numbers for RJ-45 to RJ-45 8 pin Crossover Cable for Cisco & Sun Netra: .....	23
RJ-11 Software Handshaking (XON/XOFF) Cable.....	23
Simple Software Handshaking Terminal/Printer Cable (RJ-11).....	23
RJ-45 8 pin Plug Hardware Handshaking (DTR) Cable .....	23
Terminal/Printer Cable with DTR Handshaking .....	24
RJ-45 8 pin Plug Hardware Handshaking (RTS/CTS) Cable .....	24
Terminal/Printer Cable with DTR Handshaking .....	24
RJ-45 8-Wire ALTPIN Terminal/Printer Cable.....	24
ALTPIN Terminal/Printer Cable for Software (XON/XOFF) or Hardware (RTS/CTS) Handshaking .....	25
RJ-45 Fully-Wired Terminal/Printer Cable.....	25
Terminal/Printer Cable for Software (XON/XOFF) or Hardware (RTS/CTS) Handshaking .....	26
RJ-45 8 pin to Modem (ALTPIN option).....	26
8-Wire Modem Cable Supporting ALTPIN Option .....	26
RJ-45 10 pin Plug to DB-25 Modem Cable .....	27
RJ-45 to DB-25 Modem Cable (10-Wire).....	27
RJ-45 8 pin Crossover Cable for Cisco and Sun Netra .....	27
RJ-45 to RJ-45 8 pin Crossover Cable .....	27
Pin Positions for RJ-45 .....	28

## Chapter 5 EIA-422 Asynchronous Interface

General EIA-422 Cable Information .....	29
Physical Cable Characteristics .....	29
Interface Signaling .....	29
Grounding Requirements.....	29
Digi EIA-422 Connector Wiring.....	29
EIA-422 Pinouts for DB-9, DB-25 and RJ-45 Connectors .....	30
EIA-422 Software Handshaking (XON/XOFF) Cable .....	30
EIA-422 Hardware Handshaking (Ready/Busy) Cable.....	31
EIA-422 DTE to DCE (Modem) Cable .....	31

## Chapter 6 EIA-485 Asynchronous Interface

General EIA-485 Cable Information .....	33
Physical Cable Characteristics .....	33
Interface Signaling .....	33
Grounding Requirements.....	33
Termination Information.....	33
Digi EIA-485 Connector Wiring.....	34

RJ-45 Pinouts .....	34
DB-9 Pinouts.....	34
RJ-45 8 Pin EIA-485 Multi-drop Mode .....	35

## **Chapter 7 DataFire 2000 Sync Adapter**

Introduction.....	37
Features.....	37
Cabling Information .....	37
Recommendations .....	38
X.21 Pinouts .....	38
X.21, Male DB-15 Connector .....	38
V.35 Pinouts .....	39
V.35, Male 34-pin Connector .....	39
EIA-232/V.28 Pinouts .....	39
EIA-232 / V.28 (V.24), Male DB-25 Connector .....	39
EIA-530/422 Pinouts.....	40
EIA-530/422, Male DB-25 Connector .....	40

## **Chapter 8 Pinout Reference**

Async Cable Part Numbers .....	41
Asynchronous Cabling.....	41
Cable Wall Mount Options.....	42
Cross Reference Cable to Order Numbers and ID Numbers .....	43
EIA 232 Information.....	48
RS 232 Flow Control Primer.....	48
Fiber Optic.....	49
Loopback Connector Pinouts.....	51
EtherLite RJ-45 to DB-25M Modem Adapter .....	52
EtherLite RJ-45 to DB-25M 4-Wire Cable (RS-422) .....	53
EtherLite RJ-45 to DB-25M Console Adapter.....	54
EtherLite RJ-45 to DB-9F Console Adapter.....	55
EtherLite and SCSI Terminal Server RJ-45 to DB-9M Modem Cable .....	56
EtherLite and SCSI Terminal Server RJ-45 to DB-9F Terminal Emulator Cable .....	57
EtherLite and SCSI Terminal Server RJ-45 to DB-25M Modem Cable ....	58
EtherLite RJ-45 to DB-25M DTE Modtap Adapter .....	59
EtherLite RJ-45 to DB-25M DCE Modtap Adapter .....	60
EtherLite RJ-45 to DB-9F DCE Modtap Adapter .....	61
EtherLite and SCSI Terminal Server RJ-45 to RJ-45 Cisco Console Adapter 62	
EtherLite and SCSI Terminal Server RJ-45 to DB-25M Terminal Printer Cable .....	63
Digi One, PortServer TS, and Multi-Port Serial Cards RJ-45 to DB-9F Cable Adapter .....	64
Digi One, PortServer TS, and Multi-Port Serial Cards RJ-45 to DB-25M Console Adapter .....	65
Digi One, PortServer TS, and Multi-Port Serial Cards RJ-45 to DB-25F Cable Adapter.....	66
Digi One, PortServer TS, and Multi-Port Serial Cards RJ-45 to DB-25M	

Modem Adapter .....	67
Digi One, PortServer TS, and Multi-Port Serial Cards RJ-45 to DB-9M Modem Adapter .....	68
Digi One, PortServer TS, and Multi-Port Serial Cards RJ-45 to DB-25M Printer Adapter.....	69
Digi CM RJ-45 to DB-9F DTE RS-232 Crossover Cable .....	70
Digi CM RJ-45 to DB-25M Modem Adapter.....	71
Digi CM RJ-45 to DB-9F Console Adapter .....	72
Digi CM RJ-45 to DB-25M Console Adapter .....	73
Digi CM RJ-45 to DB-25F Console Adapter .....	74
Digi CM RJ-45 to DB-9M Modem Adapter.....	75
Digi CM RJ-45 to DB-25M (DCE RS 232) Straight-Through Cable .....	76
Digi CM RJ-45 to DB-25M (DTE RS 232) Crossover Cable .....	77
Digi CM RJ-45 to RJ-45 Sun Netra or Cisco Crossover Cable.....	78
Digi CM RJ-45 to Sun Mini Din Cable.....	79
Async Conversion RJ-XX to DB-XX .....	81
Cable Vendors .....	82
DataFire Sync 2000 SCSI Pinouts.....	83
Digi One EM DB-9 Connector Pinouts.....	84
Digi One IA RealPort DB-9 Connector Pinout .....	85
Digi One EM DB-9 and Terminal Block Pinout .....	86
Digi One SP DB-9 Pinout.....	87
Async EIA-422 DB-9 Connector Pinout .....	88
Async EIA-422 DB-25 Pinout.....	89
Async RJ-45 to RJ-45 Crossover Cable .....	90
DB-25F to RJ-45 Cisco Console Cable Adapter.....	91
SCSI Terminal Server DB-25M to RJ-45 Cisco Console Cable Adapter ..	92
Difference Between DTE and DCE.....	93
DB-9F to RJ-45 3 COM Total Control/COMPAQ Microcom Modem Cable ..	94
SCSI Terminal Server DB-25M to RJ-45 3 COM Total Control/COMPAQ Microcom Modem Cable .....	95
DB-25F to RJ-45 3 COM Total Control/COMPAQ Microcom Modem Cable	96
RJ-45 to RJ-45 (Altpin On) 3 COM Total Control/COMPAQ Microcom Modem Cable .....	97
RJ-45 10 Pin to RJ-45 3 COM Total Control/Compaq Microcom Modem Cable .....	98
DB-9F to DB-9M Modem Cable .....	99
DB-9F to DB-25M Modem Cable .....	100
DB-25F to DB-9M Modem Cable .....	101
DB-25F to DB-25M Modem Cable.....	102
SCSI Terminal Server DB-25M to DB-9M Modem Cable .....	103
RJ-45 (Altpin On) to DB-9M Modem Cable .....	104
RJ-45 (Altpin On) to DB-25M Modem Cable .....	105
RJ-45 10 Pin to DB-9M Modem Cable .....	106
RJ-45 10 Pin to DB-25M Modem Cable .....	107
DB-9F to DB-9F Terminal Emulator Cable .....	108
DB-9F to DB-25F Terminal Emulator Cable .....	109
DB-25F to DB-9F Terminal Emulator Cable .....	110
DB-25F to DB-25F Terminal Emulator Cable .....	111
SCSI Terminal Server DB-25M to DB-9F Terminal Emulator Cable.....	112

SCSI Terminal Server DB-25M to DB-25F Terminal Emulator Cable.....	113
RJ-11 6 Pin/4-Wire to DB-9F Terminal Emulator Cable .....	114
RJ-11 6 Pin/4-Wire to DB-25F Terminal Emulator Cable Software Flow Control Only .....	115
RJ-11 6 Pin to DB-9F Terminal Emulator Cable .....	116
RJ-11 6 Pin to DB-25F Terminal Emulator Cable .....	117
RJ-45 4-Wire to DB-9F Terminal Emulator Cable Software Flow Control Only .....	118
RJ-45 4-Wire to DB-25F Terminal Emulator Cable Software Flow Control Only .....	119
RJ-45 (Altpin On) to DB-9F Terminal Emulator Cable .....	120
RJ-45 (Altpin On) to DB-25F Terminal Emulator Cable .....	121
RJ-45 to DB-9F Terminal Emulator Cable .....	122
RJ-45 10 Pin to DB-9F Terminal Emulator Cable .....	123
RJ-45 10 Pin to DB-25F Terminal Emulator Cable .....	124
RJ-45 (Altpin On) to RJ-45 Cisco Console Adapter .....	125
V.35 to DB-25M Cabling .....	126
V.35 Pinout .....	127
X.21 V.11 to DB-15 Cable .....	128
Digi AccelePort Xp and NEO HD-68 Pin Ultra SCSI Connector .....	129
Sync V.24 DB-25 Connector Pinout .....	132
EIA 422 DB-25 Pinouts for Sync Boards .....	133
Sync 2000 Single Port V.36/EIA-449 Pinout.....	134
DB-9F to DB-9M Terminal Printer Cable .....	136
DB-9F to DB-25M Terminal Printer Cable .....	137
DB-25F to DB-9M Terminal Printer Cable .....	138
DB-25F to DB-25M Terminal Printer Cable .....	139
SCSI Terminal Server DB-25M to DB-9M Terminal Printer Cable.....	140
SCSI Terminal Server DB-25M to DB-25M Terminal Printer Cable.....	141
RJ-11 6 Pin/4-Wire to DB-9M Terminal Printer Cable .....	142
RJ-11 6 Pin/4-Wire to DB-25M Terminal Printer Cable .....	143
RJ-11 6 Pin to DB-9F Terminal Printer Cable.....	144
RJ-11 6 Pin to DB-25M Terminal Printer Cable .....	145
RJ-45 4-Wire to DB-9M Terminal Printer Cable Software Flow Control Only	146
RJ-45 4-Wire to DB-25M Terminal Printer Cable .....	147
RJ-45 (Altpin On) to DB-9M Terminal Printer Cable .....	148
RJ-45 to DB-25M Terminal Printer Cable .....	149
RJ-45 to DB-9M Terminal Printer Cable .....	150
RJ-45 10 Pin to DB-9M Terminal Printer Cable .....	151
RJ-45 10 Pin to DB-25M Terminal Printer Cable .....	152





**General EIA-232 Cable Information**

Use this information to determine the proper EIA-232 cable requirements for your application.

**Physical Cable Characteristics**

EIA-232 serial interface cables should be shielded, low capacitance cables, designed specifically for serial data transmission.

**Grounding Requirements**

EIA-232 interface cables should have the shield grounded at both ends of the cable. Digi recommends Chassis Ground, available on the shell of Digi's DB-25 connectors, and pin 4 of a 10 pin RJ-45 connector.

**Environmental Requirements**

While good shielding provides reasonable protection against "noise" (electromagnetic interference, or EMI), cables should still be routed away from noise sources wherever possible. Avoid laying cables in close proximity to transformers, generators, motors, fluorescent lights, etc.

**Data Rate Information**

The maximum data rate that can be used for EIA-232 connections is primarily determined by the quality and length of the interconnecting cable. The quality of the cable (for transmission purposes) is generally determined by the capacitance per foot rating of the cable.

The following table gives the recommended maximum cable length for a given data rate. Longer cables may be implemented at your discretion. Note that not all Digi products support all of the data rates listed below.

**Data Rate vs. Cable Length**

Data Rate (bps)	Maximum Cable Length
57,600 or less	100 feet
115,200	80 feet
230,400	40 feet
460,800	20 feet
921,600	10 feet

**Notes:**

- The maximum length is the amount of cable that is connected to a Digi supplied interconnect device, such as Quad or Octa cables and boxes.
- The maximum length is based on a cable rated at the following:  
12.3 pF/foot, conductor to conductor  
22.4 pF/foot conductor to shield

- In situations where low-capacitance cable is unavailable, or very long cable runs are required, "short-haul" modems can be used to increase the effective range of the EIA-232 interface. Short-haul modems are similar to standard modems, except that they are connected directly to each other via a cable instead of going through a telephone circuit.
- Use only externally-powered short-haul modems with Digi products.

#### **Transmission Errors**

If transmission errors occur, follow this procedure to determine the cause of the problem:

1. Reduce the baud rate.
2. Reduce the cable length.
3. Use a cable with a lower capacitance per foot rating.

### Digi DB-25 Connector Pin Assignments

Signal	Description	DTE Use	Pin #
GND	Chassis Ground	N/A	Shell
TxD	Transmitted Data	Output	2
RxD	Received Data	Input	3
RTS	Request to Send	Output	4
CTS	Clear to Send	Input	5
DSR	Data Set Ready	Input	6
SG	Signal Ground	reference	7
DCD	Data Carrier Detect	Input	8
DTR	Data Terminal Ready	Output	20
RI	Ring Indicator	Input	22

### DB-25 Software Handshaking (XON/XOFF) Cable

The following three-wire cable is often sufficient for a terminal, printer, or other DTE device configured for software flow control.

#### Simple Terminal/Printer Cable

DB-25 Female (Digi End)			DB-25 Male (Peripheral)	
Signal	Pin		Pin	Signal
TxD	2	connected to	3	RxD
RxD	3	connected to	2	TxD
SG	7	connected to	7	SG
GND	shell	connected to (via shield)	shell	GND

This cable is a three-wire null modem cable. Transmitted Data on one end of the cable is connected to Received Data at the other end, and vice versa. The male DB-25 end can be plugged directly into most serial terminals and printers without any adapters. The female DB-25 end plugs directly into any Digi DB-25 serial port.

### DB-25 4-Wire Hardware Handshaking (DTR) Cable

The following four-wire cable is often sufficient for an older terminal, printer, or other DTE device configured for DTR (hardware) flow control. However, some terminals and printers may use a signal other than DTR for flow control. In addition, some terminals and printers may have other cable requirements. Consult your terminal or printer manual for this information. For more universal compatibility, use a full-wired DB-25 terminal/printer cable.

### Terminal/Printer Cable with DTR Handshaking

DB-25 Female (Digi End)			DB-25 Male (Peripheral)	
Signal	Pin		Pin	Signal
TxD	2	connected to	3	RxD
RxD	3	connected to	2	TxD
CTS	5	connected to	20	DTR
SG	7	connected to	7	SG
GND	Shell	connected (via shield) to	Shell	GND
	jumpered	4+5	RTS+CTS	

**Note:** Some terminal or printer manufacturers may use different methods of flow control. Consult your documentation for specific wiring requirements.

### DB-25 Hardware Handshaking (RTS/CTS) Cable

The following cable is often sufficient for a terminal, printer, or other DTE device configured for RTS/CTS (hardware) flow control. However, some terminals and printers may have other cable requirements. Consult your terminal or printer manual for this information. For more universal compatibility, use a fully-wired DB-25 terminal/printer cable.

### Terminal/Printer Cable with RTS/CTS Handshaking

DB-25 Female (Digi End)			DB-25 Male (Peripheral)	
Signal	Pin		Pin	Signal
TxD	2	connected to	3	RxD
RxD	3	connected to	2	TxD
RTS	4	connected to	5	CTS
CTS	5	connected to	4	RTS
DSR+DCD	6+8	connected to	20	DTR
SG	7	connected to	7	SG
DTR	20	connected to	6+8	DSR+DCD
GND	Shell	connected (via shield) to	Shell	GND

**Note:** Some terminal or printer manufacturers may use different methods of flow control. Consult your documentation for specific wiring requirements.

## DB-25 Fully-Wired Terminal/Printer Cable

The following cable wiring supports most serial terminals or printers with either software or hardware handshaking. This cable is valid with any Digi DB-25 serial port.

Terminal/Printer Cable for Software (XON/XOFF) or Hardware (DTR) Handshaking

DB-25 (Digi End)			DB-25 Male (Terminal/Printer)	
Signal	Pin		Pin	Signal
RTS	4	connected to	5	CTS
GND	Shell	connected to	Shell	GND
TxD	2	connected to	3	RxD
RxD	3	connected to	2	TxD
SG	7	connected to	7	SG
CTS	5	connected to	20	DTR
DTR	20	connected to	8+6	DCD+DSR
DCD+DSR	8+6	connected to	4	RTS

**Note:** Some terminal or printer manufacturers may use different methods of flow control. Consult your documentation for specific wiring requirements.

## DB-25 Modem Cable

To connect a DB-25 equipped asynchronous adapter to a modem, use a standard "straight-through" cable. A straight-through cable has a DB-25 female connector at the Digi end, and a DB-25 male connector at the modem end. All 25 pins are connected, 1 to 1, 2 to 2, 3 to 3, etc. Use shielded cable, and connect pin 1 of each connector to the cable shield.





## Cable-to-Adapter Cross Reference

For Digi One, PortServer TS, PortServer II, and Multi-Port Adapters with RJ-45 connectors

RJ45 to	Male or Female	Straight or Crossover	Application	Cable or Adapter	Part Number	Cable Identifier
DB9	F	Crossover	Bay Accelar, Nortel and other DB9 DTE devices	Cable	<a href="#">76000645</a> (4')	61090048
				Adapter (4-Pack)	<a href="#">76000697</a>	NA
DB9	M	Crossover	DTE devices with DB9 Female Ports	Cable	<a href="#">76000264</a> (4')	61080048
				Adapter	none	NA
DB9	F	Straight	Modems and other DCE devices with DB9 Male Ports	Cable	<a href="#">76000200</a> (2') <a href="#">76000201</a> (4')	61070024 61070048
				Adapter	none	NA
DB9	M	Straight	Modems and other DCE devices with DB9 Female Ports	Cable	<a href="#">76000239</a> (2') <a href="#">76000240</a> (4')	61060024 61060048
				Adapter (4-Pack)	<a href="#">76000701</a>	NA
DB25	M	Crossover	Sun Sparc, Sun Ultra, terminals, printers and other DTE devices with DB25 Female ports	Cable	<a href="#">76000238</a> (4')	61040048
				Adapter (4-Pack)	<a href="#">76000698</a>	NA
DB25	F	Crossover	Cisco, IBM and other DTE devices with DB25 Male ports	Cable	<a href="#">76000644</a> (4')	61050048
				Adapter (4-Pack)	<a href="#">76000699</a>	NA
DB25	M	Straight	Modems and other DCE devices with DB25 Female Ports	Cable	<a href="#">76000129</a> (2') <a href="#">76000195</a> (4')	61020024 61020048
				Adapter (4-Pack)	<a href="#">76000700</a>	NA
DB25	F	Straight	Modems and other DCE devices with DB25 Male Ports	Cable	<a href="#">76000198</a> (2') <a href="#">76000199</a> (4')	61030024 61030048
				Adapter	None	NA
DB25	M	* Special *	For use with Printers. This cable utilizes the DTR signal (instead of RTS) for hardware flow control.	Cable	<a href="#">76000643</a> (2')	63000196-01
				Adapter (4-Pack)	<a href="#">76000692</a>	NA
RJ45	M	* Special *	For use with Cisco and Sun RJ45 Console ports.	Cable	<a href="#">76000631</a> (6') <a href="#">76000632</a> (qty 8) <a href="#">76000633</a> (qty 16)	63000222-02
				Adapter	None	NA



### Digi DB-9 Connector Options: AccelePort Xr, Xe, ClassicBoard

#### Fan-Out Cables

AccelePort and ClassicBoard adapters may be equipped with a fan-out cable consisting of a single DB-78M connector at the adapter end, and four or eight DTE-wired DB-9 male or female connectors at the peripheral end.

**Note:** **IMPORTANT!** The Digi Neo and AccelePort Xp families use different cable assemblies from those used with ClassicBoard and other Digi adapters (AccelePort Xr, Xe, PC/X). When ordering, be sure to use the part number that corresponds to your adapter type.

#### Part Numbers for DB-9 Fan-Out Cables (Standard AccelePort DB-78 Connector)

Cable Description	Order Number	Number found on Cable
4 Port DB-9M (Male) DTE Cable	76000003	60000211
4 Port DB-9F (Female) DTE Cable	76000001	60000241
8 Port DB-9M (Male) DTE Cable	76002042	63000205-01

### DB-9 Connector Options: Digi Neo, AccelePort Xp

#### Fan-Out Cables

Digi Neo and AccelePort Xp adapters may be equipped with a fan-out cable consisting of a single connector at the adapter end, and four or eight DTE-wired DB-9 male or female connectors at the peripheral end. Two 8-port fan-out cables may be used with 16-port adapters.

**Note:** **IMPORTANT!** The Digi Neo and AccelePort Xp families use different cable assemblies from those used with ClassicBoard and other Digi adapters (Xr, Xe, C/X, Xem, PC/X). When ordering, be sure to use the part number that corresponds to your adapter type. If you already have connector assemblies for older adapters and wish to use them with a Digi Neo or AccelePort Xp adapter, a converter cable may be purchased (see below for part number).

#### Part Numbers for DB-9 Fan-Out Cables (Xp and Neo - 68 pin SCSI Connector)

Cable Description	Order Number	Number found on Cable
4 Port DB-9M (Male) DTE Cable	76000528	63000183-02
4 Port DB-9F (Female) DTE Cable	76000530	63000186-02
8 Port DB-9M (Male) DTE Cable	76000529	63000183-01
8 Port DB-9M (Female) DTE Cable	76000531	63000186-01

## Connector Boxes

Digi connector box assemblies consist of a single HD-68M connector at the adapter end, connected by a 6-foot cable to a connector box equipped with four or eight DTE-wired DB-9 male connectors. AccelePort 16p adapters have two connectors, which may be connected to two 8-port boxes or a 16-port rack-mount box. AccelePort 16p adapters include two 10-foot cables. 10-foot cables may be ordered as an upgrade option for 4- and 8-port adapters.

**Note:** **IMPORTANT!** The Digi Neo and AccelePort Xp families use different cable assemblies from those used with ClassicBoard and other Digi adapters (Xr, Xe, C/X, Xem, PC/X). When ordering, be sure to use the part number that corresponds to your adapter type. If you already have connector assemblies for older adapters and wish to use them with a Digi Neo or AccelePort Xp adapter, a converter cable may be purchased (see below for part number).

**Part Numbers for DB-9 Connector Boxes (Xp and Neo - 68 pin SCSI Connector) :**

Cable Description	Order Number	Number found on Cable
4 Port DB-9M (Male) DTE Box	76000560	63000188-02
8 Port DB-9M (Male) DTE Box	76000561	63000188-02

**Part Numbers for Cable Options :**

Cable Description	Order Number	Number found on Cable
10-Foot Cable Upgrade Option (68 pin Connectors)	76000559	63000188-02
HD-68M to DB-78F Converter	76000534	63000191-01

## DB-9 Software Handshaking (XON/XOFF) Cable

The following three-wire cable is often sufficient for a terminal, printer, or other DTE device configured for software flow control.

**Simple Terminal/Printer Cable**

DB-9 Female (Digi End)			DB-9 Male (Peripheral)	
Signal	Pin		Pin	Signal
TxD	3	connected to	2	RxD
RxD	2	connected to	3	TxD
SG	5	connected to	5	SG
GND	Shell	connected (via shield) to	Shell	GND

This cable is a three-wire null modem cable. Transmitted Data on one end of the cable is connected to Received Data at the other end, and vice versa. The male DB-9 end can be plugged directly into most serial terminals and printers without any adapters. The female DB-9 end plugs directly into any Digi DB-9 serial port.

## DB-9 4-Wire Hardware Handshaking (DTR) Cable

The following four-wire cable is often sufficient for a terminal, printer, or other DTE device configured for DTR (hardware) flow control. However, some terminals and printers may have other cable requirements. Consult your terminal or printer manual for this information. For more universal compatibility, use a fully-wired DB-9 terminal/printer cable .

### Terminal/Printer Cable with DTR Handshaking

DB-9 Female (Digi End)			DB-9 Male (Peripheral)	
Signal	Pin		Pin	Signal
RxD	2	connected to	3	TxD
TxD	3	connected to	2	RxD
SG	5	connected to	5	SG
CTS	8	connected to	4	DTR
GND	Shell	connected (via shield) to	Shell	GND
		jumpered	7+8	RTS+CTS

### Digi DB-9 Connector Pin Assignments

Signal	Description	DTE Use	Pin #
GND	Chassis Ground	N/A	Shell
DCD	Data Carrier Detect	Input	1
RxD	Received Data	Input	2
TxD	Transmitted Data	Output	3
DTR	Data Terminal Ready	Output	4
SG	Signal Ground	reference	5
DSR	Data Set Ready	Input	6
RTS	Request to Send	Output	7
CTS	Clear to Send	Input	8
RI	Ring Indicator	Input	9

### DB-9 Modem Cable

To connect a DB-9 equipped asynchronous adapter to a modem, use a standard "straight-through" cable. A straight-through cable has a DB-9 female connector at the Digi end, and a DB-9 male connector at the modem end. All 9 pins are connected, 1 to 1, 2 to 2, 3 to 3, etc. Use shielded cable, and connect pin 1 of each connector to the cable shield.

### Fully-Wired DB-9 Terminal/Printer Cable

The following cable wiring supports most serial terminals or printers with either software or hardware handshaking. This cable is valid with any Digi DB-9 serial port.

Most terminals and printers use Request to Send/Clear to Send (RTS/CTS) for hardware handshaking. The following cable wiring supports this method.

**Terminal/Printer Cable for Software (XON/XOFF) or Hardware (RTS/CTS) Handshaking**

DB-9 (Digi End)			DB-9 Male (Terminal/Printer)	
Signal	Pin		Pin	Signal
DCD+DSR	1+6	connected to	4	DTR
RxD	2	connected to	3	TxD
TxD	3	connected to	2	RxD
DTR	4	connected to	1+6	DCD+DSR
SG	5	connected to	5	SG
RTS	7	connected to	8	CTS
CTS	8	connected to	7	RTS
GND	Shell	connected to	Shell	GND

**Note:** Important: Other printer manufacturers may use different methods of flow control. Consult your printer's documentation for specific wiring requirements.

**DB-9 Hardware Handshaking (RTS/CTS) Cable**

The following cable is often sufficient for a terminal, printer, or other DTE device configured for RTS/CTS (hardware) flow control. However, some terminals and printers may have other cable requirements. Consult your terminal or printer manual for this information. For more universal compatibility, use a fully-wired DB-9 terminal/printer cable.

**Terminal/Printer Cable with RTS/CTS Handshaking**

DB-9 Female (Digi End)			DB-9 Male (Peripheral)	
Signal	Pin		Pin	Signal
RxD	2	connected to	3	TxD
TxD	3	connected to	2	RxD
SG	5	connected to	5	SG
RTS	7	connected to	8	CTS
CTS	8	connected to	7	RTS
GND	Shell	connected (via shield) to	Shell	GND

### Digi RJ-45 Connector Pin Assignments

10 pin RJ-45 plugs may be difficult to obtain in the retail market; therefore, most Digi device driver software incorporates an optional feature called ALTPIN, which swaps the logical functions of DSR (Data Set Ready) with DCD (Data Carrier Detect).

When ALTPIN is enabled, DCD becomes available on pin 1 of an 8 pin RJ-45 connector (equivalent to pin 2 of a 10 pin connector).

Signal	Description	DTE Use	Pin #
RI	Ring Indicator	Input	1
DSR (DCD <sup>a</sup> )	Data Set Ready (Data Carrier Detect <sup>a</sup> )	Input	2
RTS	Request to Send	Output	3
GND	Chassis Ground	N/A	4
TxD	Transmitted Data	Output	5
RxD	Received Data	Input	6
SG	Signal Ground	reference	7
CTS	Clear to Send	Input	8
DTR	Data Terminal Ready	Output	9
DCD (DSR <sup>a</sup> )	Data Carrier Detect (Data Set Ready <sup>a</sup> )	Input	10

a. When ALTPIN is in effect.

### RJ Connector Types

The following table shows the relationship of various RJ plugs to the Digi RJ-45 10 pin jack. The Digi 10 pin jack can accept any of the listed plug types. The wiring of each plug type corresponds to support of specific capabilities such as software handshaking, hardware handshaking, and the Digi ALTPIN feature.

Digi 10 pin Jack	Signal Name	RJ-45 10 pin Plug	RJ-45 8 pin Plug	RJ-11 6-Pin Plug	RJ-11 4-Pin Plug
1	RI	1			
2	DSR (DCD <sup>*</sup> ) <sup>*</sup> When ALTPIN is in effect.	2	1		
3	RTS	3	2	1	
4	GND	4	3	2	1
5	TxD	5	4	3	2
6	RxD	6	5	4	3

7	SG	7	6	5	4
8	CTS	8	7	6	
9	DTR	9	8		
10	DCD (DSR*) *When ALTPIN is in effect.	10			

### Digi RJ-45 to DB-25/DB-9 Cable Adapters

RJ-45 to DB-25/DB-9 cable adapters can be purchased from Digi. These adapters consist of a 10 pin RJ-45 plug connected via a two- or four-foot cable to a DB-25 or DB-9 connector. The adapters are fully-wired and provide modem control.

#### Part numbers for RJ-45 to DB-25 Cable Adapters:

Cable Description	Order #	Number found on Cable
Cable RJ45 to DB25M ( Male) DTE 24"	76000129	61020024
Cable RJ45 to DB25F (Female) DTE 24"	76000198	61030024
Cable RJ45 to DB25M ( Male) DTE 48"	76000195	61020048
Cable RJ45 to DB25M ( Male) DCE 48"	76000238	61040048
Cable RJ45 to DB25F (Female) DTE 48"	76000199	63000205-01

#### Part numbers for RJ-45 to DB-9 Cable Adapters:

Cable Description	Order #	Number found on Cable
Cable RJ45 to DB9M ( Male) DTE 24"	76000239	61060024
Cable RJ45 to DB9F (Female) DTE 24"	76000200	61070024
Cable RJ45 to DB9M ( Male) DTE 48"	76000240	61060048
Cable RJ45 to DB9M ( Male) DCE 48"	76000264	61080048
Cable RJ45 to DB9F (Female) DTE 48"	76000201	61070048

### Digi RJ-45 to RJ-45 Cable Adapters: 8 Pin

RJ-45 to RJ-45 cable adapters can be purchased from Digi. These adapters consist of an 8 pin RJ-45 plug connected to another 8 pin RJ-45 plug with a crossover cable. These cables are used to connect the Digi devices to the serial console port of Cisco and Sun Netra devices. Pinout information and a graphic is included later in this chapter. See "RJ-45 8 pin Crossover Cable for Cisco and Sun Netra" on page 27 for pinout and graphic information.

**Part numbers for RJ-45 to RJ-45 8 pin Crossover Cable for Cisco & Sun Netra:**

Cable Description	Order #	Number found on Cable
Cable RJ45 to RJ45 8 pin (single pack)	76000631	63000222-02
Cable RJ45 to RJ45 8 pin (bulk pack of 8)	76000632	63000222-02
Cable RJ45 to RJ45 8 pin (bulk pack of 16)	76000633	63000222-02

**RJ-11 Software Handshaking (XON/XOFF) Cable**

The following 3-wire cable is often sufficient for a terminal, printer or other DTE device configured for software flow control.

**Simple Software Handshaking Terminal/Printer Cable (RJ-11)**

RJ-11 (Digi End)			DB-25 Male (Peripheral)	
Signal	Pin		Pin	Signal
TxD	2	connected to	3	RxD
RxD	3	connected to	2	TxD
SG	4	connected to	7	SG
GND	1	connected (via shield) to	1 (or shell)	GND

This cable is a 3-wire null modem cable. Transmitted Data on one end of the cable is connected to Received Data at the other end and vice versa. The RJ-11 plug fits into the center of the RJ-45 jack. The male DB-25 end can be plugged directly into most serial terminals and printers without any adapters.

An RJ-45 8 pin connector uses the same wiring with the center pins only—pins 3, 4, 5, and 6. See the section titled RJ Connector Types for a comparison of various RJ connector types that work with the Digi 10 pin RJ-45 jack.

**RJ-45 8 pin Plug Hardware Handshaking (DTR) Cable**

Using an 8 pin plug, the following cable wiring is often sufficient for a terminal, printer, or other DTE device configured for DTR (hardware) flow control. However, some terminals and printers may use a signal other than DTR for flow control. In addition, some terminals and printers may have other cable requirements. Consult your terminal or printer manual for this information. For more universal compatibility, use the RJ-45 10-wire terminal/printer cable or a Digi RJ-45 to DB-25 adapter.

### Terminal/Printer Cable with DTR Handshaking

RJ-45 (Digi End)			DB-25 Male (Peripheral)	
Signal	Pin		Pin	Signal
TxD	4	connected to	3	RxD
RxD	5	connected to	2	TxD
CTS	7	connected to	20	DTR
SG	6	connected to	7	SG
GND	3	connected (via shield) to	1 (or shell)	GND
	jumpered	4+5	RTS+CTS	

**Note:** Some terminal or printer manufacturers may use different methods of flow control. Consult your documentation for specific wiring requirements.

### RJ-45 8 pin Plug Hardware Handshaking (RTS/CTS) Cable

Using an 8 pin plug, the following cable wiring is often sufficient for a terminal, printer, or other DTE device configured for RTS/CTS (hardware) flow control. However, some terminals and printers may have other cable requirements. Consult your terminal or printer manual for this information. For more universal compatibility, use the RJ-45 10-wire terminal/printer cable or a Digi RJ-45 to DB-25 adapter.

### Terminal/Printer Cable with DTR Handshaking

RJ-45 (Digi End)			DB-25 Male (Peripheral)	
Signal	Pin		Pin	Signal
DSR	1	connected to	20	DTR
RTS	2	connected to	5	CTS
GND	3	connected (via shield) to	1 (or shell)	GND
TxD	4	connected to	3	RxD
RxD	5	connected to	2	TxD
SG	6	connected to	7	SG
CTS	7	connected to	4	RTS
DTR	8	connected to	8	DCD

**Note:** Some terminal or printer manufacturers may use different methods of flow control. Consult your documentation for specific wiring requirements.

### RJ-45 8-Wire ALTPIN Terminal/Printer Cable



Using an 8 pin RJ-45 plug, the following cable wiring supports most serial terminals or printers with either software or hardware handshaking using the Digi ALTPIN option.

Most terminals and printers use Request to Send/Clear to Send (RTS/CTS) for hardware handshaking. The cable shown supports this method.

**ALTPIN Terminal/Printer Cable for Software (XON/XOFF) or Hardware (RTS/CTS) Handshaking**

RJ-45 8 pin (Digi End)			DB-25 Male (Terminal/Printer)	
Signal	Pin		Pin	Signal
DCD*	1	connected to	20	DTR
* ALTPIN must be turned on for pin 1 to be DCD. When ALTPIN is enabled, DCD becomes available on pin 1 of an 8 pin RJ-45 connector (equivalent to pin 2 of a 10 pin connector).				
RTS	2	connected to	5	CTS
GND	3	connected (via shield) to	Shell	GND
TxD	4	connected to	3	RxD
RxD	5	connected to	2	TxD
SG	6	connected to	7	SG
CTS	7	connected to	4	RTS
DTR	8	connected to	6+8	DSR+DCD

**Note:** Some terminal or printer manufacturers may use different methods of flow control. Consult your documentation for specific wiring requirements.

**RJ-45 Fully-Wired Terminal/Printer Cable**

Using a 10 pin RJ-45 plug, the following cable wiring supports most serial terminals or printers with either software or hardware handshaking. This cable is valid with any Digi RJ-45 serial port.

Most terminals and printers use Request to Send/Clear to Send (RTS/CTS) for hardware handshaking. The cable shown supports this method.

**Terminal/Printer Cable for Software (XON/XOFF) or Hardware (RTS/CTS) Handshaking**

RJ-45 10 pin (Digi End)			DB-25 Male (Terminal/Printer)	
Signal	Pin		Pin	Signal
DSR+DCD* * ALTPIN must be turned off for DCD to be on pin 10	2+10	connected to	20	DTR
RTS	3	connected to	5	CTS
GND	4	connected (via shield) to	Shell	GND
TxD	5	connected to	3	RxD
RxD	6	connected to	2	TxD
SG	7	connected to	7	SG
CTS	8	connected to	4	RTS
DTR	9	connected to	6+8	DSR+D CD

**Note:** Some terminal or printer manufacturers may use different methods of flow control. Consult your documentation for specific wiring requirements.

**RJ-45 8 pin to Modem (ALTPIN option)**

The following table shows how to build an 8-wire modem cable using an 8 pin RJ-45 plug. This cable supports the Digi ALTPIN option when plugged into a Digi RJ-45 serial port.

**8-Wire Modem Cable Supporting ALTPIN Option**

RJ-45 (Digi End)			DB-25 Male (Modem End)	
Signal	Pin		Pin	Signal
DCD	1	connected to	8	DCD
RTS	2	connected to	4	RTS
GND	3	connected (via shield) to	1 (or shell)	GND
RxD	5	connected to	3	RxD
TxD	4	connected to	2	TxD
SG	6	connected to	7	SG
CTS	7	connected to	5	CTS
DTR	8	connected to	20	DTR

When ALTPIN is enabled, DCD becomes available on pin 1 of an 8 pin RJ-45 connector (equivalent to pin 2 of a 10 pin connector).

**Note:** ALTPIN is not supported for the PortServer product under Windows NT. Use a full 10-wire modem cable in this case.

### RJ-45 10 pin Plug to DB-25 Modem Cable

The simplest way to connect a modem to a Digi RJ-45 jack is to use a Digi RJ-45 to DB-25 Cable Adapter. The following table shows how to apply the adapter wiring scheme to custom modem cables.

#### RJ-45 to DB-25 Modem Cable (10-Wire)

RJ-45 (Digi End)			DB-25 Male (Modem End)	
Signal	Pin		Pin	Signal
RI	1	connected to	22	RI
DSR	2	connected to	6	DSR
RTS	3	connected to	4	RTS
GND	4	connected (via shield) to	1 (or shell)	GND
TxD	5	connected to	2	TxD
RxD	6	connected to	3	RxD
SG	7	connected to	7	SG
CTS	8	connected to	5	CTS
DTR	9	connected to	20	DTR
DCD	10	connected to	8	DCD

### RJ-45 8 pin Crossover Cable for Cisco and Sun Netra

Below is the pinout information for an RJ-45 8 pin crossover cable for Cisco and Sun Netra serial console ports. Also included is a graphic detailing pin positions on the RJ-45 plug.

#### RJ-45 to RJ-45 8 pin Crossover Cable

from RJ-45 port	Signal		Signal	to Cisco/SunNetra RJ-45 port
4	TxD	connected to	RxD	6
5	RxD	connected to	TxD	3
6	GND	connected to	GND	4
8	DTR	connected to	DSR	7
1	DSR	connected to	DTR	2
2	RTS	connected to	CTS	8
7	CTS	connected to	RTS	1

**Pin Positions for RJ-45**

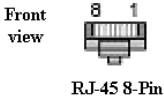
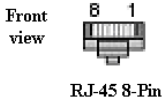

**RJ-45 8-Pin Crossover Cable**

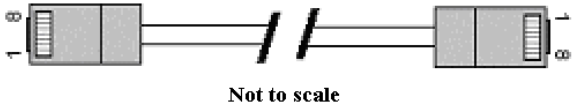

**General EIA-422 Cable Information**

This section applies to Digi products equipped with EIA-422 asynchronous interfaces.

**Physical Cable Characteristics**

EIA-422 interface cables should be shielded twisted-pair cables. Each signal requires two leads (one twisted pair of wires) to complete a balanced voltage digital circuit. The shield should be connected to the Chassis Ground of the devices at *both* ends of the interface cable.

**Interface Signaling**

The EIA-422 interface provides four signals: Transmitted Data (TxD), Received Data (RxD), Request To Send (RTS) and Clear To Send (CTS). The functions of these signals are identical to their EIA-232 counterparts.

**Grounding Requirements**

EIA-422 interface cables must provide a ground path between the devices to be connected. This ensures the integrity of data transfers and control signals. This should be connected to the Chassis Ground of each device. Digi recommends using the cable shield for this purpose.

**Digi EIA-422 Connector Wiring**

A terminal, a serial printer, or a serial port for another computer usually functions as a DTE device. The Digi adapter is also a DTE device. To connect a DTE device to another DTE device a null modem cable or adapter must be used.

Two wires (one twisted pair) are required for each signal, a positive lead ("+"), and a negative lead ("-"). The "+" leads at one end of the cable must be connected to the "+" leads at the other end, and the "-" leads at one end must be connected to the "-" leads at the other end.

Incorrect wiring could result in damage to the connected devices. The following table shows the pin configurations for the EIA-422 versions of Digi DB-9, DB-25, and RJ-45 connectors.

### EIA-422 Pinouts for DB-9, DB-25 and RJ-45 Connectors

Signal	Description	DB-9 Pin	DB-25 Pin	RJ-45 10 Pin
TxD+	Transmitted Data (+)	3	2	5
TxD-	Transmitted Data (-)	9	14	1
RxD+	Received Data (+)	2	3	6
RxD-	Received Data (-)	6	16	2
RTS+	Request To Send (+)	7	4	3
RTS-	Request To Send (-)	4	19	9
CTS+	Clear To Send (+)	8	5	8
CTS-	Clear To Send (-)	1	13	10
GND	Chassis Ground	Shell	Shell	4
SG	Signal Ground	5	-	7

### EIA-422 Software Handshaking (XON/XOFF) Cable

Use the chart below as a guide for EIA-422 wiring. Pin numbers have been omitted because they vary from product to product. For Digi pin numbers, see the section titled "Digi EIA-422 Connector Wiring" on page 29. For peripheral device pin numbers, see the documentation for your peripheral device.

DTE (Digi End)			DTE (Peripheral)	
Signal	Lead		Lead	Signal
TxD	+	Connected to	+	RxD
	-	Connected to	-	
RxD	+	Connected to	+	TxD
	-	Connected to	-	
GND		Connected to	-	GND
RTS	Jumpered, connect: RTS(+) to CTS(+); RTS(-) to CTS(-)		Jumpered, connect: RTS(+) to CTS(+); RTS(-) to CTS(-)	RTS
CTS				CTS

## EIA-422 Hardware Handshaking (Ready/Busy) Cable

Use the following table as a guide for EIA-422 wiring. Pin numbers have been omitted because they vary from product to product. For Digi pin numbers, see the section titled "Digi EIA-422 Connector Wiring" on page 29. For peripheral device pin numbers, see the documentation for your peripheral device.

DTE (Digi End)			DTE (Peripheral)	
Signal	Lead		Lead	Signal
TxD	+	Connected to	+	RxD
	-	Connected to	-	
RxD	+	Connected to	+	TxD
	-	Connected to	-	
RTS	+	Connected to	+	CTS
	-	Connected to	-	
CTS	+	Connected to	+	RTS
	-	Connected to	-	
GND		Connected to		GND

## EIA-422 DTE to DCE (Modem) Cable

Use the chart below as a guide for EIA-422 modem wiring. Pin numbers have been omitted because they vary from product to product. For Digi pin numbers, see the section titled "Digi EIA-422 Connector Wiring" on page 29. For modem pin numbers, see your modem's documentation.

DTE (Digi End)			DCE (Modem)	
Signal	Lead		Lead	Signal
TxD	+	Connected to	+	TxD
	-	Connected to	-	
RxD	+	Connected to	+	RxD
	-	Connected to	-	
RTS	+	Connected to	+	RTS
	-	Connected to	-	
CTS	+	Connected to	+	CTS
	-	Connected to	-	
GND		Connected to		GND





**General EIA-485 Cable Information**

This section applies to Digi products equipped with EIA-485 asynchronous interfaces.

**Physical Cable Characteristics**

EIA-485 interface cables should be shielded twisted-pair cables with a maximum of 4000 feet in length. Each signal requires two leads (one twisted pair of wires) to complete a balanced voltage digital circuit. The shield should be connected to the Chassis Ground of the devices at *both* ends of the interface cable.

**Interface Signaling**

The EIA-485 interface provides four signals: Transmitted Data (TxD), Received Data (RxD), Request To Send (RTS) and Clear To Send (CTS). The functions of these signals are identical to their EIA-232 counterparts.

**Grounding Requirements**

EIA-485 interface cables must provide a ground path between the devices to be connected. This ensures the integrity of data transfers and control signals. This should be connected to the Chassis Ground of each device. Digi recommends using the cable shield for this purpose.

**Termination Information**

A DIP switch controls the termination of many Digi devices. Most Digi devices use the #4 switch to control termination. When the switch is down, termination is off and there is no termination. To set termination on the device, move the #4 switch to the up position. Termination is recommended in a multi-drop line for the last networked device. Termination also biases the line.

Check your Digi device for its ohm rating, but 100 ohms is the nominal setting in Digi products.

## Digi EIA-485 Connector Wiring

Two wires (one twisted pair) are required for each signal, a positive lead ("+"), and a negative lead ("-"). The "+" leads at one end of the cable must be connected to the "+" leads at the other end, and the "-" leads at one end must be connected to the "-" leads at the other end.

Incorrect wiring could result in damage to the connected devices. The following tables show the pin configurations for the EIA-485 versions of Digi DB-9 and RJ-45 10 pin connectors.

### RJ-45 Pinouts

RJ-45 Pin	485 Half Duplex	485 Full Duplex	Signal Description
1	TxD-	TxD-	Transmitted Data (-)
2	RxD-	RxD-	Received Data (-)
3	n/a	RTS+	Request To Send (+)
4	GND	GND	Chassis Ground
5	TxD+	TxD+	Transmitted Data (+)
6	RxD+	RxD+	Received Data (+)
7	SG	SG	Signal Ground
8	n/a	CTS+	Clear To Send (+)
9	n/a	RTS-	Request To Send (-)
10	n/a	CTS-	Clear To Send (-)

### DB-9 Pinouts

DB-9 Pin	Screw Term	485 Half Duplex	485 Full Duplex	Signal Description
1	9	Not used	CTS-	Clear To Send (-)
2	6	RxD+	RxD+	Received Data (+)
3	3	TxD+	TxD+	Transmitted Data (+)
4	2	Not used	RTS-	Request To Send (-)
5	5	GND	GND	Chassis Ground
6	7	RxD-	RxD-	Received Data (-)
7	1	Not used	RTS+	Request To Send (+)
8	8	Not used	CTS+	Clear To Send (+)
9	4	TxD-	TxD-	Transmitted Data (-)

## RJ-45 8 Pin EIA-485 Multi-drop Mode

### Digi EIA-485 Connector Wiring

Use the table below to see the pin assignments for the RJ-45 connector for EIA-485 multi-drop mode.

EtherLite 2 EIA-485 ports are wired for half duplex multiple-drop EIA-485 mode and have no termination installed.

Signal	Description	RJ-45 Pin
-	no connection	1
-	no connection	2
-	no connection	3
TxD(A)/RxD(A)	Transmitted/Received Data (A)	4
TxD(B)/RxD(B)	Transmitted/Received Data (B)	5
GND	Ground	6
-	no connection	7
-	no connection	8

---



**Introduction**

The DataFire SYNC 2000 adapter is an intelligent, high performance synchronous communications adapter that is available in versions for PCI bus and Compact PCI (cPCI) bus compatible systems. The basic design comes with a Motorola MPC860 PowerQUICC<sup>®</sup> (Quad Integrated Communications Controller), with an integrated PowerPC<sup>®</sup> RISC processor providing four SCCs on the four-port adapter and two SCCs on the two-port adapter.

DataFire SYNC 2000 adapters offer a Universal Interface Bus (UIB) capable of supporting a different interface on each port. The UIB automatically configures the electrical interface of a port based on the type of Digi cable connected to the port. That is, you can select an interface type for a port just by connecting the appropriate cable between the adapter and the peripheral device. You can use any combination of interface types to connect up to two peripherals to the two-port version, or up to four peripherals to the four-port version.

**Features**

The DataFire SYNC 2000 adapter has the following features:

- High-speed synchronous communications ports
- Automatic cable detection
- SurgeBlock<sup>®</sup> surge protection
- All major electrical interfaces are available as UIB cable options, including X.21, V.28 (V.24)/EIA-232, V.35/RS-449, V.36, EIA-422, and EIA-530
- Available with an optional PowerPC 603 processor, 4 megabytes of RAM, and Frame Relay or X.25 public data network protocols
- The DataFire SYNC 2000 adapter has gained homologation acceptance for most European countries

**Cabling Information**

Each cable provided by Digi has a 68 pin Ultra SCSI connector on one end, which attaches to a port on the Universal Interface Bus. The other end of the cable will provide signals according to the interface standards.

Each port on the SYNC 2000 adapter can be configured to use any one of a number of cables. Cables are available as V.35, EIA-530/EIA-422, X.21, and EIA-232/V.28. The cable type is automatically detected by the Universal Interface Bus.

If you require multiple cables of one type, you may order additional cables from Digi. To extend the length of a Digi cable, use standard interface cabling between the end of Digi's cable and the peripheral.

### Recommendations

Digi recommends shielded cables (15 pF or less capacitance per foot) for all installations.

The FCC requires the use of shielded cables to comply with EMI/RFI emission limits. In addition, cables that run long distances or through electrically noisy areas are subject to voltage surges that can cause data errors or equipment damage. EIA-232 specifies a maximum cable length of 50 feet. If you run cables farther than 50 feet, you increase the risk of surge damage and data loss. (However, using shielded cable of 10-15 pF capacitance per foot somewhat lessens the risk of data errors.)

When routing your cables, do not run them parallel to AC wiring or on top of fluorescent light ballasts. Bundling several EIA-232 cables is acceptable

## X.21 Pinouts

### X.21, Male DB-15 Connector

Pin	CCITT	Description
9	103B	TxD-
2	103A	TxD+
3	105B	RTS-
10	105A	RTS+
4	104A	RxD-
11	104B	RxD+
5	106A	CTS-
12	106B	CTS+
13	115A	RxCLKi-
6	115B	RxCLKi+
7	113A	TxCLKo-
14	113B	TxCLKo+
8	n/a	GND
Shell	n/a	CGND

## V.35 Pinouts

### V.35, Male 34-pin Connector

Pin	CCITT	Description
A	n/a	CGND
B	n/a	GND
C	105	RTS
D	106	CTS
E	107	DSR
F	109	DCD
H	108	DTR
P	103A	TxD-
S	103B	TxD+
R	104A	RxD-
T	104B	RxD+
V	115A	RxCLKi-
X	115B	RxCLKi+
Y	114A	TxCLKi-
AA	114B	TxCLKi+
U	113A	TxCLKo-
W	113B	TxCLKo+

## EIA-232/V.28 Pinouts

### EIA-232 / V.28 (V.24), Male DB-25 Connector

Pin	CCITT	Description
2	103	TxD
3	104	RxD
15	114	TxCLKi
17	115	RxCLKi
4	105	RTS
5	106	CTS
Shell	n/a	CGND
20	108	DTR
6	107	DSR
8	109	DCD
24	113	TxCLKo
25	125	RI
7	n/a	GND

## EIA-530/422 Pinouts

### EIA-530/422, Male DB-25 Connector

Pin	CCITT	Desc.
2	103A	TxD-
14	103B	TxD+
3	104A	RxD-
16	104B	RxD+
15	114A	TxCLKi-
12	114B	TxCLKi+
17	115A	RxCLK-
9	115B	RxCLK+
4	105A	RTS-
19	105B	RTS+
5	106A	CTS-
13	106B	CTS+
20	108A	DTE Ready-
23	108B	DTE Ready+
6	107A	DCE-
22	107B	DCE+
8	109A	RLSD-
10	109B	RLSD+
24	113A	TxCLKo-
11	113B	TxCLKo+
7	n/a	GND
Shell	n/a	CGND
25	142	Test Mode



## Async Cable Part Numbers

Description	DTE Digi Part Number	DTE Cable ID Number	DCE Digi Part Number
<b>Digi Quad Cable</b>			
DB-9M	76000003	60000211	N/A
DB-9F	76000001	--	N/A
DB-25M	76000008	-	76000007
DB-25F	76000006	--	76000005
<b>Digi Quad Box</b>			
DB-25M	760000030	--	760000028
DB-25F	760000026	--	760000024
<b>Digi Octa Cable</b>			
DB-9M	76002042	--	N/A
DB-9F	76000013	--	N/A
DB-25M	76000021	60000183	76000020
DB-25F	76000019	--	76000018
<b>Digi Octa Box</b>			
DB-25M	76000031	--	76000029
DB-25F	76000027	--	76000025
<b>RJ-45 Connector Box</b>			
Quad	76000038	--	--
Octa	76000033	--	--
<b>Digi Converter Options</b>			
RJ-45 to DB-9M	(24") 76000239	--	N/A
RJ-45 to DB-9F	(24") 76000200	--	N/A
RJ-45 to DB-9M	(48") 76000240	--	76000264
RJ-45 to DB-9F	(48") 76000201	61070048	--
RJ-45 to DB-25M	(24") 76000129	--	N/A
RJ-45 to DB-25F	(24") 76000198	--	N/A
RJ-45 to DB-25M	(48") 76000195	--	76000238
RJ-45 to DB-25F	(48") 76000199	61050048-	--
<b>EtherLite and SCSI</b>			
RJ-45 to DB-25M	76000450	--	76000451
DB-9F to RJ-45	76000461	--	N/A
SCSI-2 3' Cable	76000449	--	--

## Asynchronous Cabling

Description	Digi Order Number	Cable ID Number
<b>Non-Intelligent Board Cables</b>		

Description	Digi Order Number	Cable ID Number
• ClassicBoard ISA		
ClassicBoard 16 (16654) Cable	--	62080060
• PC/X		
PC/16 Ribbon Cable	10000358 10000359	--
PC/4 or PC/8 (2 Boards) Daisy Chain Cable	--	60000186
PC/4 or PC/8 (3 Boards) Daisy Chain Cable	--	60000196
PC/4 or PC/8 (4 Boards) Daisy Chain Cable	--	60000197
PC/16 (2 Boards) Daisy Chain Cable	--	60000268
<b>Intelligent Board Cables</b>		
• PC/XE and PC/XI Ribbon Cables		
PC/16e (RJ-45)	10000475 10000476	--
PC/16e and PC/16i (DB-25)	10000390 10000414	--
• Xem EBI Cables		
16" Cable (DB-44)	--	62080016
60" Cable (DB-44)	--	62080060
• C/X and EPC/X Connectors		
Old 10' Cable (MtoM) HD-15	--	62020120
New 10' Cable (MtoF) HD-15	--	62110120
FL Adapter Domestic Fiber Connector	76000071	--
• EIA-232 Remote Cabling		
Host Adapter to Sync Modem	76000211	6240060
Host Sync Modem to Remote	76000212	6241060
• PortServer II Cables		
RJ-45 to DB-25 Cable 4'	--	61020004
*RJ-45 to DB-25M Sync Shield Cable 24" *This cable is only required for Frame Relay	76000252	--

## Cable Wall Mount Options

Description	Digi Order Number
4 Port RJ-45 Wall Mount	76000180
8 Port RJ-45 Wall Mount	76000181

## Cross Reference Cable to Order Numbers and ID Numbers

Device	Click on Description to See Pinout	Part Number <small>*To order Digi Cable or Adapter</small>	Cable ID <small>*Labeled on Cable or Adapter</small>
<b>EtherLite Cables</b>	EtherLite RJ-45 to DB-25M Modem Adapter	76000450	
	EtherLite RJ-45 to DB-25M 4-Wire Cable (RS-422)		
	EtherLite RJ-45 to DB-25M Console Adapter	76000451	
	EtherLite RJ-45 to DB-9F Console Adapter	76000461	
	EtherLite and SCSI Terminal Server RJ-45 to DB-9M Modem Cable	76000200 24" 76000201 48"	
	EtherLite and SCSI Terminal Server RJ-45 to DB-9F Terminal Emulator Cable	76000645 48"	
	EtherLite and SCSI Terminal Server RJ-45 to DB-25M Modem Cable	76000195	
	EtherLite RJ-45 to DB-25M DTE Modtap Adapter	76000672	
	EtherLite RJ-45 to DB-25M DCE Modtap Adapter	76000670	
	EtherLite RJ-45 to DB-9F DCE Modtap Adapter	76000702	
	EtherLite and SCSI Terminal Server RJ-45 to RJ-45 Cisco Console Adapter	76000631	
	EtherLite and SCSI Terminal Server RJ-45 to DB-25M Terminal Printer Cable	76000643	

Device	Click on Description to See Pinout	Part Number *To order Digi Cable or Adapter	Cable ID *Labeled on Cable or Adapter	
<b>Digi One, PortServer TS, and Multi-Port Serial Card Adapters</b>	Digi One, PortServer TS, and Multi-Port Serial Cards RJ-45 to DB-9F Cable Adapter	Adapter -4 pak 76000697	N/A	
		Crossover Cable - 4' 76000645	61090048	
	Digi One, PortServer TS, and Multi-Port Serial Cards RJ-45 to DB-9F Modem Adapter and Straight-through Cable	Adapter - None	N/A	
		Straight-through Cable -2' 76000200	61070024	
		Straight-through Cable -4' 76000201	61070048	
	Digi One, PortServer TS, and Multi-Port Serial Cards RJ-45 to DB-9M Modem Adapter and Crossover Cable	Adapter - None	N/A	
		Crossover Cable - 4' 76000264	61080048	
	Digi One, PortServer TS, and Multi-Port Serial Cards RJ-45 to DB-25M Printer Adapter and Cable	Adapter - 4 pak 76000692	N/A	
		Cable - 2' 76000643	63000196-01	
	Digi One, PortServer TS, and Multi-Port Serial Cards RJ-45 to DB-25M Console Adapter	Adapter - 4 pak 76000699	N/A	
		Crossover Cable - 4' 76000644	61050048	
	Digi One, PortServer TS, and Multi-Port Serial Cards RJ-45 to DB-25M Modem Adapter and Crossover Cable	Adapter - 4 pak 76000698	N/A	
		Crossover Cable -4' 76000238	61040048	
	Digi One, PortServer TS, and Multi-Port Serial Cards RJ-45 to DB-25F Cable Adapter	Adapter - None	N/A	
		Straight-through Cable 2' 76000198	61030024	
		Straight-through Cable 4' 76000195	61020048	
	<b>Digi CM Cables and Adapters</b>	Digi CM RJ-45 to DB-9F DTE RS-232 Crossover Cable		
		Digi CM RJ-45 to DB-25M Modem Adapter	76000670 -8 pak	63000074-01
		Digi CM RJ-45 to DB-9F Console Adapter	76000671 -8 pak	63000075-01
		Digi CM RJ-45 to DB-25M Console Adapter	76000672 -8 pak	
Digi CM RJ-45 to DB-25F Console Adapter		76000673 -8 pak	63000076-01	
Digi CM RJ-45 to DB-9M Modem Adapter		76000702 -8 pak		
Digi CM RJ-45 to DB-25M (DCE RS 232) Straight-Through Cable		76000700		
Digi CM RJ-45 to DB-25M (DTE RS 232) Crossover Cable		76000008	63000074-01	
Digi CM RJ-45 to RJ-45 Sun Netra or Cisco Crossover Cable		76000631 76000632 (8 pak) 76000633 (16 pak)		
Digi CM RJ-45 to Sun Mini Din Cable				

<b>Device</b>	<b>Click on Description to See Pinout</b>	<b>Part Number</b> *To order Digi Cable or Adapter	<b>Cable ID</b> *Labeled on Cable or Adapter
<b>Digi One EM</b>	Digi One EM DB-9 Connector Pinouts		63000058-01
	Digi One EM DB-9 and Terminal Block Pinout		63000066-01 63000070-01
<b>Digi One IA RealPort</b>	Digi One IA RealPort DB-9 Connector Pinout		63000084-01
<b>Digi One SP</b>	Digi One SP DB-9 Pinout		63000058-01 63000066-01 63000070-01
<b>DataFire Sync 2000 X.21 V.11 to DB-15 Cable</b>	DataFire Sync 2000 SCSI Pinouts		
	EIA 422 DB-25 Pinouts for Sync Boards		
	Sync V.24 DB-25 Connector Pinout		
	Sync 2000 Single Port V.36/EIA-449 Pinout		
	Sync 2000 Single Port X.21 V.11 DB-15 Cable	77000426	
	Sync 570i UIB 2 Port X.21 V.11 DB-15 Cable	76000294	
	Sync 570i 2 Port X.21 V.11 DB-15 Cable		62500038
	Sync 570i 4 Port (3 Port X.21 V.11 DB-15) Cable		62500048
	Sync 570i 4 Port X.21 V.11 DB-15 Cable		62500047
<b>Async</b>	Async Conversion RJ-XX to DB-XX	--	--
	Async EIA-422 DB-9 Connector Pinout	76000003	
	Async EIA-422 DB-25 Pinout	76000008	
	Async RJ-45 to RJ-45 Crossover Cable	76000031	
<b>Cisco Console Cable Adapter or Cable</b>	DB-25F to RJ-45 Cisco Console Cable Adapter		
	SCSI Terminal Server DB-25M to RJ-45 Cisco Console Cable Adapter		
	RJ-45 (Altpin On) to RJ-45 Cisco Console Adapter		
	Digi CM RJ-45 to RJ-45 Sun Netra or Cisco Crossover Cable	76000631 76000632 (8 pak) 76000633 (16 pak)	63000222-02
<b>3 COM Total Control/COMPAQ Microcom Modem Cable</b>	SCSI Terminal Server DB-25M to RJ-45 3 COM Total Control/COMPAQ Microcom Modem Cable	76000451	
	DB-9F to RJ-45 3 COM Total Control/COMPAQ Microcom Modem Cable		
	DB-25F to RJ-45 3 COM Total Control/COMPAQ Microcom Modem Cable		
	RJ-45 to RJ-45 (Altpin On) 3 COM Total Control/COMPAQ Microcom Modem Cable	76000631 76000632 (8 pak) 76000633 (16 pak)	
	RJ-45 10 Pin to RJ-45 3 COM Total Control/Compaq Microcom Modem Cable	76000566	63000182-01

Device	Click on Description to See Pinout	Part Number *To order Digi Cable or Adapter	Cable ID *Labeled on Cable or Adapter
<b>Modem Cables</b>	DB-9F to DB-9M Modem Cable		
	DB-9F to DB-25M Modem Cable		
	DB-25F to DB-9M Modem Cable		
	DB-25F to DB-25M Modem Cable		
	SCSI Terminal Server DB-25M to DB-9M Modem Cable		
	RJ-45 (Altpin On) to DB-9M Modem Cable	76000239	61090048
	RJ-45 (Altpin On) to DB-25M Modem Cable	76000129	61020024
	RJ-45 10 Pin to DB-9M Modem Cable RJ-45 10 Pin to DB-25M Modem Cable		
<b>Terminal Emulator Cable</b>	DB-9F to DB-9F Terminal Emulator Cable		
	DB-9F to DB-25F Terminal Emulator Cable		
	DB-25F to DB-9F Terminal Emulator Cable		
	DB-25F to DB-25F Terminal Emulator Cable		
	SCSI Terminal Server DB-25M to DB-9F Terminal Emulator Cable		
	SCSI Terminal Server DB-25M to DB-25F Terminal Emulator Cable		
	RJ-11 6 Pin/4-Wire to DB-9F Terminal Emulator Cable		
	RJ-11 6 Pin/4-Wire to DB-25F Terminal Emulator Cable Software Flow Control Only		
	RJ-11 6 Pin to DB-9F Terminal Emulator Cable		
	RJ-11 6 Pin to DB-25F Terminal Emulator Cable		
	RJ-45 4-Wire to DB-9F Terminal Emulator Cable Software Flow Control Only		
	RJ-45 4-Wire to DB-25F Terminal Emulator Cable Software Flow Control Only		
	RJ-45 (Altpin On) to DB-9F Terminal Emulator Cable		
	RJ-45 (Altpin On) to DB-25F Terminal Emulator Cable		
	RJ-45 to DB-9F Terminal Emulator Cable		
	RJ-45 10 Pin to DB-9F Terminal Emulator Cable	Crossover Cable -4' 76000645	61090048
RJ-45 10 Pin to DB-25F Terminal Emulator Cable			
<b>Miscellaneous</b>	V.35 to DB-25M Cabling		
	V.35 Pinout		62500075 62500076
	Digi AccelePort Xp and NEO HD-68 Pin Ultra SCSI Connector		63000188-03

<b>Device</b>	<b>Click on Description to See Pinout</b>	<b>Part Number</b> <small>*To order Digi Cable or Adapter</small>	<b>Cable ID</b> <small>*Labeled on Cable or Adapter</small>
<b>Terminal Printer Cable</b>	DB-9F to DB-9M Terminal Printer Cable		
	DB-9F to DB-25M Terminal Printer Cable		
	DB-25F to DB-9M Terminal Printer Cable		
	SCSI Terminal Server DB-25M to DB-9M Terminal Printer Cable		
	SCSI Terminal Server DB-25M to DB-25M Terminal Printer Cable		
	RJ-11 6 Pin/4-Wire to DB-9M Terminal Printer Cable		
	RJ-11 6 Pin/4-Wire to DB-25M Terminal Printer Cable		
	RJ-11 6 Pin to DB-9F Terminal Printer Cable		
	RJ-11 6 Pin to DB-25M Terminal Printer Cable		
	RJ-45 4-Wire to DB-9M Terminal Printer Cable Software Flow Control Only		
	RJ-45 4-Wire to DB-25M Terminal Printer Cable	76000238	
	RJ-45 (Altpin On) to DB-9M Terminal Printer Cable		
	RJ-45 to DB-25M Terminal Printer Cable	76000643	
	RJ-45 to DB-9M Terminal Printer Cable		
	RJ-45 10 Pin to DB-9M Terminal Printer Cable		
RJ-45 10 Pin to DB-25M Terminal Printer Cable			
<b>SCSI Terminal Server Cable and Adapters</b>	SCSI Terminal Server DB-25M to DB-9F Terminal Emulator Cable		
	SCSI Terminal Server DB-25M to DB-25F Terminal Emulator Cable		
	SCSI Terminal Server DB-25M to DB-9M Terminal Printer Cable		
	SCSI Terminal Server DB-25M to DB-25M Terminal Printer Cable		
	Digi AccelePort Xp and NEO HD-68 Pin Ultra SCSI Connector		63000188-03
	SCSI Terminal Server DB-25M to RJ-45 Cisco Console Cable Adapter		
	SCSI Terminal Server DB-25M to RJ-45 3 COM Total Control/COMPAQ Microcom Modem Cable		

## RS

# RS-232 Flow Control Primer

**Hardware flow control** uses pins RTS and CTS to gate flow back and forth between two connected serial devices. The DTE device uses RTS to start and stop flow from the DCE device, and the DCE device uses CTS to gate flow from the DTE device. This method is popular for higher speed connections where flow control reaction time is more critical. It's also popular where the data stream is such that embedded flow control characters can not be tolerated by the protocol running on the link. The cost is that you have to run two more wires in the cable.

**Software flow control** uses special START (XON) and STOP (XOFF) characters embedded in the data stream to gate flow. In other words, the receiving device would send a STOP character (typically a control-s) to the sending device to halt flow. It would then later send a START character (typically a control-q) to resume flow. This method of flow control is more popular for slower links whose protocol can support embedded flow control characters. It's popular because it only requires that you run 3 wires for the link to function: Receive (RxD), Transmit (TxD), and Ground (GND).



## Fiber Optic

### Fiber Optic Cable Specifications and Source CSP

## Fiber Optic Cable Specifications and Source

CSP, Inc. can provide you with reliable fiber assemblies certified to function properly with DigiBoard equipment.

Fiber is the best solution for transmitting large amounts of data over long distances at high speeds without interference or lost data caused by outside factors such as weather, radio frequency signals or other electrical noise.

The ST connector provides these features as well as strong performance and reliability characteristics. The ST connector also helps maintain close tolerances when mating connectors in an adapter. The ST connector is easily recognizable because of its bayonet style attachment/detachment mechanism.

The ST also offers superior loss characteristics because the ferrules are made of stainless steel or ceramic and the connector has a spring-loaded mating system that exerts consistent pressure on the ferrule tip when inserted in an active device or an adjoining fiber. These impressive characteristics have allowed the ST connector to become the most widely used connector in Local Area Networks (LANs).

CSP fiber optic assemblies are made at the length you specify with or without an optional pulling eye to meet your individual requirements.

CSP assemblies are made with FDDI grade fiber and tested to meet EIA/FOTP specifications. CSP complies with the requirements of the 1990 National Electrical Code (NEC) for Optical Fiber Cables - Article 770.

### Specifications:

Fiber Type.....Glass Graded Index  
Core Diameter.....62.5 um  
Cladding Diameter.....125 um  
Tight Buffer Diameter.....900 um  
Numerical Aperture.....>.27  
Connector.....ST Stainless  
Cable Type.....Duplex (Zipcord)  
Orange Jacket

### Cable Parameters (OFNR, OFNP)

Manufacturer Montrose Montrose  
Part Number FBB-022R-2 FBB-022P-2  
Weight 15 kg/km 20 kg/km  
Diameter 3.0x6.5 mm 3.0x6.5 mm  
Jacket PVC Plenum rated

Operating Load 450N 450N  
 Installation Load 700N 700N  
 Operating Bend Radius 25 mm 25 mm  
 Installation Bend Radius 4 mm 4 mm  
 Impact Resistance 20 impacts w/1.0N-m(EIA-425-25)  
 Crush Resistance 500 N/cm 500 N/cm  
 Flexing 5000 5000  
 Operating Temperature -40 C to 85 C -40 C to 85 C  
 Storage Temperature -55 C to 85 C -55 C to 85 C  
 Flame Retard UL-1666 OFNR UL-910 OFNP

## Connector

Type ST  
 Ferrule Material Stainless Steel  
 Termination Break Strength 30 lbs.  
 Connection Loss 0.6 Typical

Wave Length	850 nm	1300 nm
Attenuation	3.25 db/km max.	1.25 db/km max.
Bandwidth	160 MHz/km	500 MHz/km

## Part Numbers

Meters	Feet	PVC Part #	Plenum Part #
1	3.28	DBI62140001	DBI62140001-P
10	32.8	DBI62140010	DBI62140010-P
50	164.04	DBI62140050	DBI62140050-P
100	328.08	DBI62140100	DBI62140100-P
250	820.2	DBI62140250	DBI62140250-P
500	1640.4	DBI62140500	DBI62140500-P
750	2460.6	DBI62140750	DBI62140750-P
1000	3280.8	DBI62141000	DBI62141000-P

Per customer order DBI6214MMMM DBI6214MMMM-P  
 Please contact Dave Beran for more information: 1-800-932-9821  
 CSP, Inc. 14305 N. 21st Avenue Minneapolis, MN 55447  
 1-800-422-2537 In MN (612) 476-6866 FAX (612) 476-6966

---

Copyright © 1996-2002 Digi International. All rights reserved.

## Loopback Connector Pinouts

DB-15M, DB-25F, DB-25F, DB-15F, DB-25F, RJ-45

## Loopback Connectors

Loopback connectors must have the following sets of pins tied together:

DB-15 EIA-232 Male	DB-25 EIA-232 Female	DB-25 V.35 Female	DB-15 X.21 Female	DB-25 EIA-530/422 Female	RJ-45 Telco
2,3	2,3	2, 3	2, 4	2, 3	1, 8
4,5	4,5	4, 5	3, 5	4, 5	2, 7
6, 8, 15	6, 8, 20	6, 8, 20	6, 7	6, 8, 20	
12,13	17, 24	9, 11	9, 11	9, 11	
		14, 16	10, 12	14, 16	
		17, 24	13, 14	17, 24	
				13, 19	
				10, 22, 23	

---

# EtherLite RJ-45 to DB-25M Modem Adapter

## Cable Adapters

### Etherlite, RJ-45 to DB-25 Modem Adapter

For use with Etherlite 2, 80, 160, 162, 32 – All Models

Digi Cable Adapters allow you to connect your serial devices using commercially available CAT 5 cable of any length. Simply plug standard CAT 5 cable into your Digi Product, connect a Cable Adapter to the other end and plug the adapter into your device.

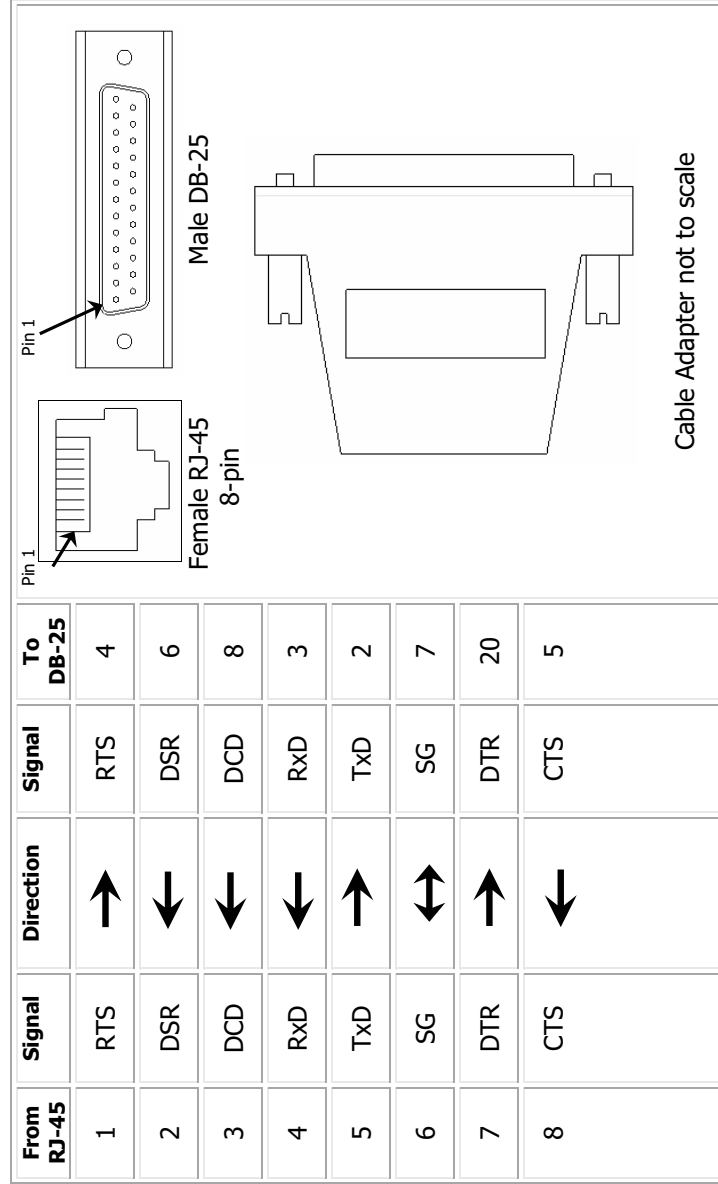

\* Arrows indicate which direction the signal is flowing

#### Notes:

- All RJ45 cable adapters are 8-pin.
- This adapter utilizes the CTS signal of the modem for hardware flow control (RTS / CTS).

Digi Part Number 76000450 Etherlite DB25M Modem Adapter (single-pack)  
90000603\_A

# EtherLite RJ-45 to DB-25M 4-Wire Cable (RS-422)

## EtherLite RS422 RJ45-DB25 pinouts

The wiring diagram for a RJ45 to DB25 4-wire full duplex cable is shown in Table 1.

**Table 1: EIA-422 RJ-45 8-pin to DB-25 cable**

From RJ-45	Signal	Signal	To DB-25
2	RxD-	TxD+	2
4	RxD+	TxD-	14
5	TxD+	RxD-	16
7	TxD-	RxD+	3

## EtherLite, RJ-45 to DB-25 Console Adapter

For use with EtherLite 2, 80, 160, 162, 32 – All Models

Digi Cable Adapters allow you to connect your serial devices using commercially available CAT 5 cable of any length. Simply plug standard CAT 5 cable into your Digi Product, connect a Cable Adapter to the other end and plug the adapter into your device.

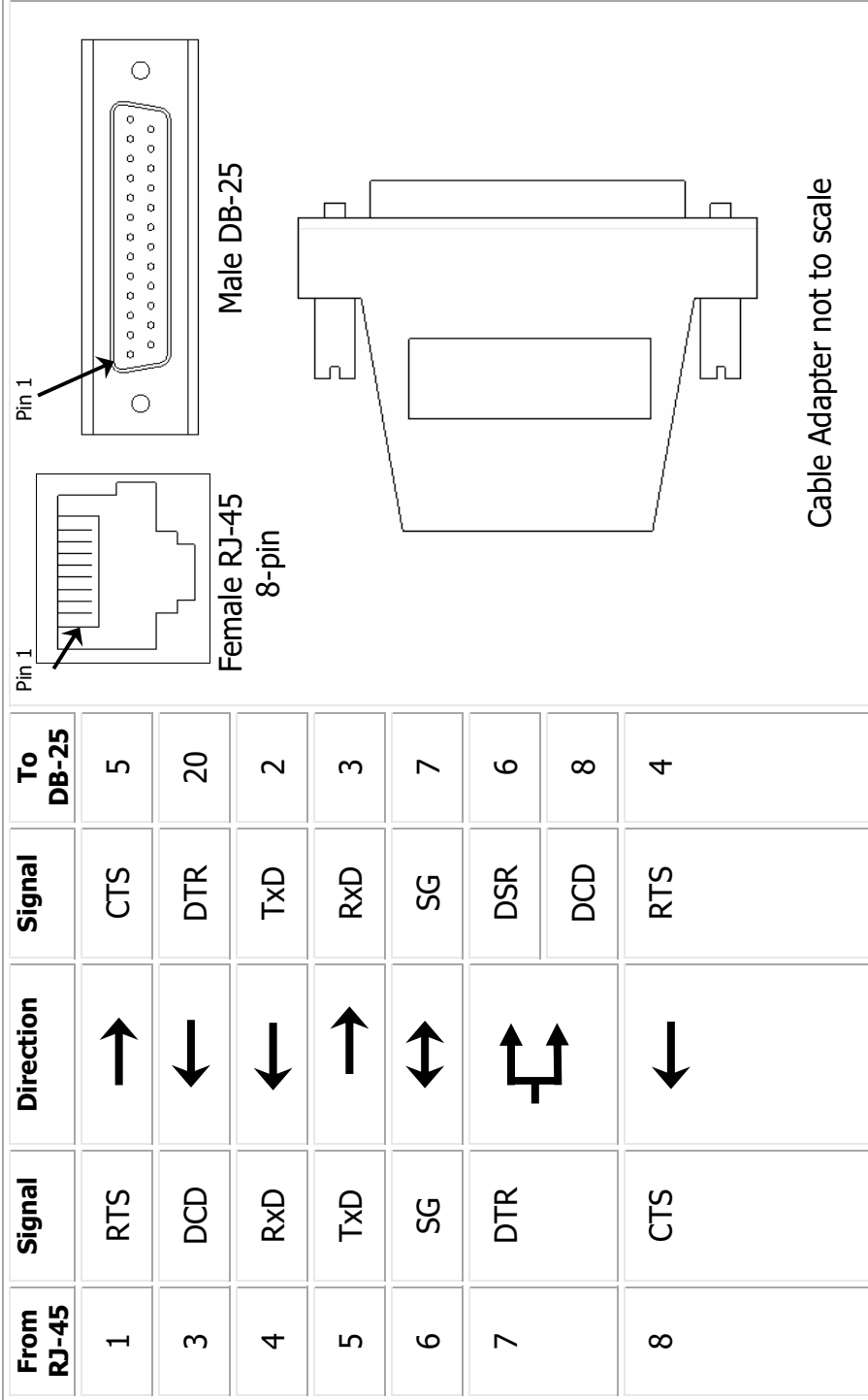

\* Arrows indicate which direction the signal is flowing

**Notes:**

- All RJ45 cable adapters are 8-pin.
- This adapter utilizes the RTS signal of the serial device for hardware flow control (RTS/CTS).

## EtherLite, RJ-45 to DB-9 Console Adapter

For use with EtherLite 2, 80, 160, 162, 32 – All Models

Digi Cable Adapters allow you to connect your serial devices using commercially available CAT 5 cable of any length. Simply plug standard CAT 5 cable into your Digi Product, connect a Cable Adapter to the other end and plug the adapter into your device.

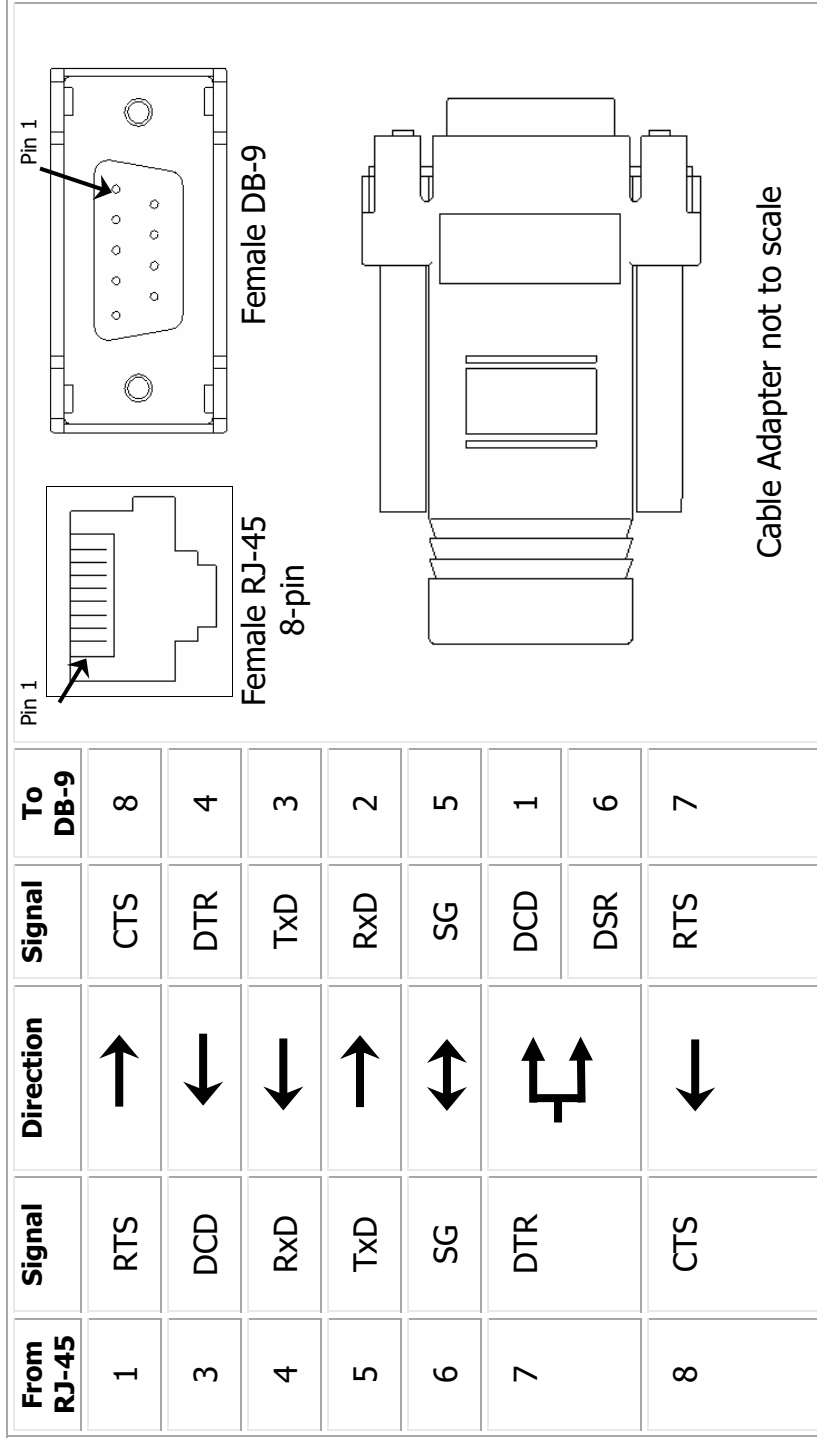

\* Arrows indicate which direction the signal is flowing

**Notes:**

- All RJ45 cable adapters are 8-pin.
- This cable utilizes the RTS signal of the serial device for hardware flow control (RTS / CTS).

Digi Part Number 76000461 EtherLite DB9F Console Adapter (single-pack)

# EtherLite and SCSI Terminal Server RJ-45 to DB-9M Modem Cable

## Modem Cables RJ-45 (Central Data) to DB-9

**EIA-232 Boards with RJ-45 (Central Data) Cable Connectors-** EtherLite 2, EtherLite 8, EtherLite 16, EtherLite 160, EtherLite 32, SCSI Terminal Server 1400, SCSI Terminal Server 1800, SCSI Terminal Server 1610, SCSI Terminal Server 1032.

The wiring diagram for an RJ-45 8-pin to DB-9 modem cable is shown in Table 1.

**Table 1: EIA-232 RJ-45 8-pin to DB-9 modem cable**

From RJ-45	Signal	Direction	Signal	To DB-9
3	DCD	←	DCD	1
4	RxD	←	RxD	2
5	TxD	→	TxD	3
7	DTR	→	DTR	4
6	SG	↔	SG	5
2	DSR	←	DSR	6
1	RTS	→	RTS	7
8	CTS	←	CTS	8
Shell	GND	↔	GND	Shell



FRONT:  
RJ-45 8-Pin

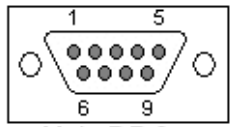

Male DB-9

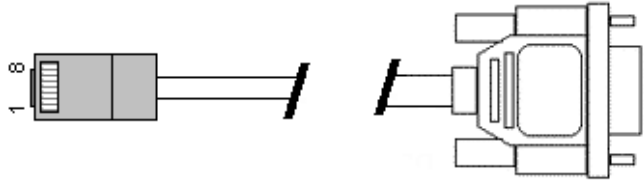

Connectors not to scale

\* Arrows indicate which direction the signal is flowing

### NOTES:

- This cable utilizes the CTS signal of the modem for hardware flow control (RTS/CTS).
- EIA-232 cables cannot exceed 2500pF.



# EtherLite and SCSI Terminal Server RJ-45 to DB-9F Terminal Emulator Cable

## Cables

### PC Terminal Emulator Cables, RJ-45 (Central Data) to DB-9

**EIA-232 Boards with RJ-45 (Central Data) Cable Connectors** - EtherLite 2, EtherLite 8, EtherLite 16, EtherLite 160, EtherLite 32, SCSI Terminal Server 1400, SCSI Terminal Server 1800, SCSI Terminal Server 1610, SCSI Terminal Server 1032.

The wiring diagram for an RJ-45 8-pin to DB-9 PC terminal emulator cable is shown in Table 1.

**Table 1: EIA-232 RJ-45 8-pin to DB-9 PC terminal emulator cable**

From RJ-45	Signal	Direction	Signal	To DB-9
4	RxD	←	TxD	3
5	TxD	→	RxD	2
7	DTR	→	DSR	6
			DCD	1
6	SG	↔	SG	5
1	RTS	→	CTS	8
8	CTS	←	RTS	7
3	DCD	←	DTR	4

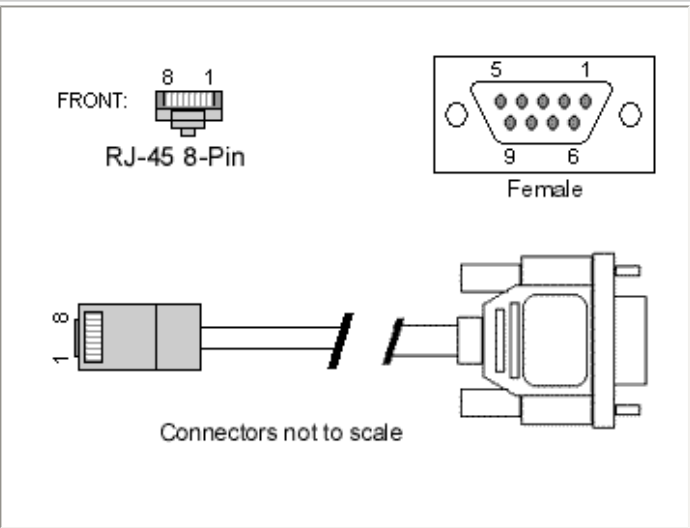

\* Arrows indicate which direction the signal is flowing

#### NOTES:

- This cable utilizes the RTS signal of the PC terminal emulator for hardware flow control (RTS/CTS).
- EIA-232 cables cannot exceed 2500pF.

## EtherLite and SCSI Terminal Server RJ-45 to DB-25M Modem Cable

### Modem Cables RJ-45 (Central Data) to DB-25

EIA-232 Boards with RJ-45 (Central Data) Cable Connectors- EtherLite 2, EtherLite 8, EtherLite 16, EtherLite 160, EtherLite 32, SCSI Terminal Server 1400, SCSI Terminal Server 1800, SCSI Terminal Server 1610, SCSI Terminal Server 1032.

The wiring diagram for an RJ-45 8-pin to DB-25 modem cable is shown in Table 1.

**Table 1: EIA-232 RJ-45 8-pin to DB-25 modem cable**

From RJ-45	Signal	Direction	Signal	To DB-25
3	DCD	←	DCD	8
4	RxD	←	RxD	3
5	TxD	→	TxD	2
7	DTR	→	DTR	20
6	SG	↔	SG	7
2	DSR	←	DSR	6
1	RTS	→	RTS	4
8	CTS	←	CTS	5
Shell	GND	↔	GND	Shell

\* Arrows indicate which direction the signal is flowing

#### NOTES:

- This cable utilizes the CTS signal of the modem for hardware flow control (RTS/CTS).
- EIA-232 cables cannot exceed 2500pF.

## EtherLite RJ-45 to DB-25M DTE Modtap Adapter

### Modtap - RJ-45f (Etherlite) to DB-25m DTE

The wiring diagram for an RJ-45 8-pin to DB-25 DTE modtap is shown in Table 1. This adapter is used to connect a modem to an Etherlite port, and is available from Digi by ordering part number 76000450.

**Table 1: EIA-232 RJ-45 8-pin to DB-25 DTE modtap**

From RJ-45	Signal	Direction	Signal	To DB-25
1	RTS	→	RTS	4
2	nc	X	DSR	6
3	DCD	←	DCD	8
4	RxD	←	RxD	3
5	TxD	→	TxD	2
6	SG	↔	SG	7
7	DTR	→	DTR	20
8	CTS	←	CTS	5

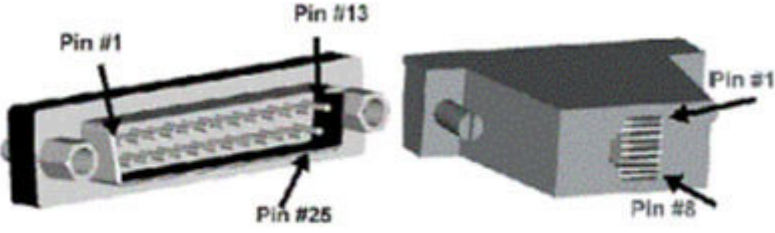

\* Arrows indicate which direction the signal is flowing

#### NOTES:

- This cable utilizes the RTS/CTS signals of the modem for hardware flow control.
- A straight-through RJ45 cable is used between Etherlite and modtap adapter.
- EIA-232 cables cannot exceed 2500pF.

## EtherLite RJ-45 to DB-25M DCE Modtap Adapter

### Modtap - RJ-45f (EtherLite) to DB-25m DCE

The wiring diagram for an RJ-45 8-pin to DB-25 DCE modtap is shown in Table 1. This adapter is used to connect a terminal/printer to an EtherLite port, and is available from Digi by ordering part number 76000451.

**Table 1: EIA-232 RJ-45 8-pin to DB-25 DCE modtap**

From RJ-45	Signal	Direction	Signal	To DB-25
1	RTS	→	CTS	5
2	nc	X	DSR	6
3	DCD	←	DTR	20
4	RxD	←	TxD	2
5	TxD	→	RxD	3
6	SG	↔	SG	7
7	DTR	→	DCD	8
8	CTS	←	RTS	4

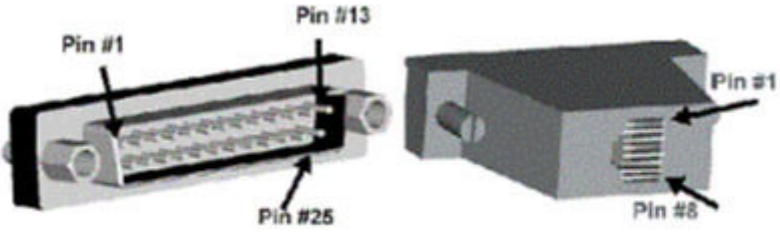

The diagram shows two views of the adapter. The left view shows the RJ-45 side with pins 1, 13, and 25 labeled. The right view shows the DB-25 side with pins 1 and 8 labeled.

\* Arrows indicate which direction the signal is flowing

#### NOTES:

- This cable utilizes the RTS/CTS signals of the terminal/printer for hardware flow control.
- Since null-modem swapping is done within the modtap, a straight-through RJ45 cable is used between EtherLite and modtap adapter.
- EIA-232 cables cannot exceed 2500pF.

# EtherLite RJ-45 to DB-9F DCE Modtap Adapter

## Modtap - RJ -45f (Ether Lite) to DB -9f DCE

The wiring diagram for an RJ-45 8-pin to DB-9 DCE modtap is shown in Table 1. This adapter is used to connect a console/com port to an EtherLite port, and is available from Digi by ordering part number 76000461.

Table 1: EIA -232 RJ -45 8-pin to DB -9 DCE modtap

From RJ - 45	Signal	Direction	Signal	To DB - 9
1	RTS	→	CTS	8
2	nc	X	DSR	6
3	DCD	←	DTR	4
4	RxD	←	TxD	3
5	TxD	→	RxD	2
6	SG	«	SG	5
7	DTR	→	DCD	1
8	CTS	←	RTS	7

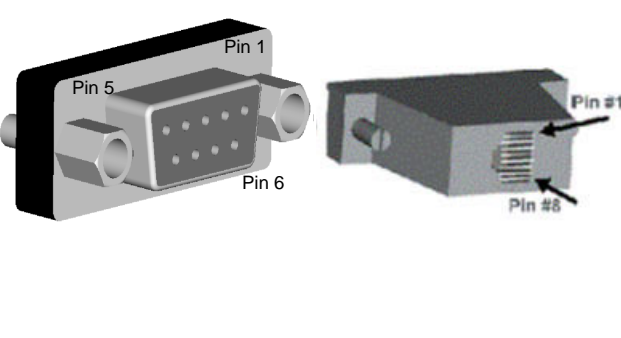

\* Arrows indicate which direction the signal is flowing

### NOTES:

- This cable utilizes the RTS/CTS signals of the console/com port for hardware flow control.
- Since null-modem swapping is done within the modtap, a straight-through RJ45 cable is used between EtherLite and modtap adapter.
- EIA-232 cables cannot exceed 2500pF.

# EtherLite and SCSI Terminal Server RJ-45 to RJ-45 Cisco Console Adapter

## Adapter Cables

### Digi - Cisco Console Adapter, RJ-45 (Central Data) to RJ-45

**EIA-232 Boards with RJ-45 Cable Connectors** - EtherLite 2, EtherLite 8, EtherLite 16, EtherLite 160, EtherLite 32, SCSI Terminal Server 1400, SCSI Terminal Server 1800, SCSI Terminal Server 1610, SCSI Terminal Server 1032.

The wiring diagram for a RJ-45 8-pin to Cisco Console RJ-45 8-pin adapter cable is shown in Table 1.

**Table 1: EIA-232 RJ-45 8-pin to RJ-45 8-pin**

From RJ-45	Signal	Direction	Signal	To RJ-45 Cisco
3	DCD	←	DTR	2
4	RxD	←	TxD	3
5	TxD	→	RxD	6
7	DTR	→	DSR	7
6	SG	↔	SG	5
1	RTS	→	CTS	8
8	CTS	←	RTS	1

- Arrows indicate which direction the signal is flowing

# EtherLite and SCSI Terminal Server RJ-45 to DB-25M Terminal Printer Cable

## Terminal/Printer Cables, RJ-45 (Central Data) to DB-25

EIA-232 Boards with RJ-45 (Central Data) Cable Connectors - EtherLite 2, EtherLite 8, EtherLite 16, EtherLite 160, EtherLite 32, SCSI Terminal Server 1400, SCSI Terminal Server 1800, SCSI Terminal Server 1610, SCSI Terminal Server 1032.

The wiring diagram for an RJ-45 8-pin to DB-25 terminal/printer cable is shown in Table 1.

**Table 1: EIA-232 RJ-45 8-pin to DB-25 terminal/printer cable**

From RJ-45	Signal	Direction	Signal	To DB-25
4	RxD	←	TxD	2
5	TxD	→	RxD	3
			DSR	6
7	DTR	→	DCD	8
6	SG	↔	SG	7
1	RTS	→	CTS	5
8	CTS	←	DTR	20
3	DCD	←	RTS	4

\* Arrows indicate which direction the signal is flowing

### NOTES:

- This cable utilizes the DTR signal of the terminal/printer for hardware flow control (RTS/CTS).
- Okidata printers may use SSD (pin 11) instead of DTR (pin 20) on DB25 side of above diagram. If this is the case, the printer should be set to SSD+.
- EIA-232 cables cannot exceed 2500pF.

## Digi TS, RJ-45 to DB-9 Console Adapter

For use with Digi One TS, Portserver TS 2/4/8/16, and Multi-Port Serial Cards with RJ45 connectors

Digi Cable Adapters allow you to connect your serial devices using commercially available CAT 5 cable of any length. Simply plug standard CAT 5 cable into your Digi Product, connect a Cable Adapter to the other end and plug the adapter into your device.

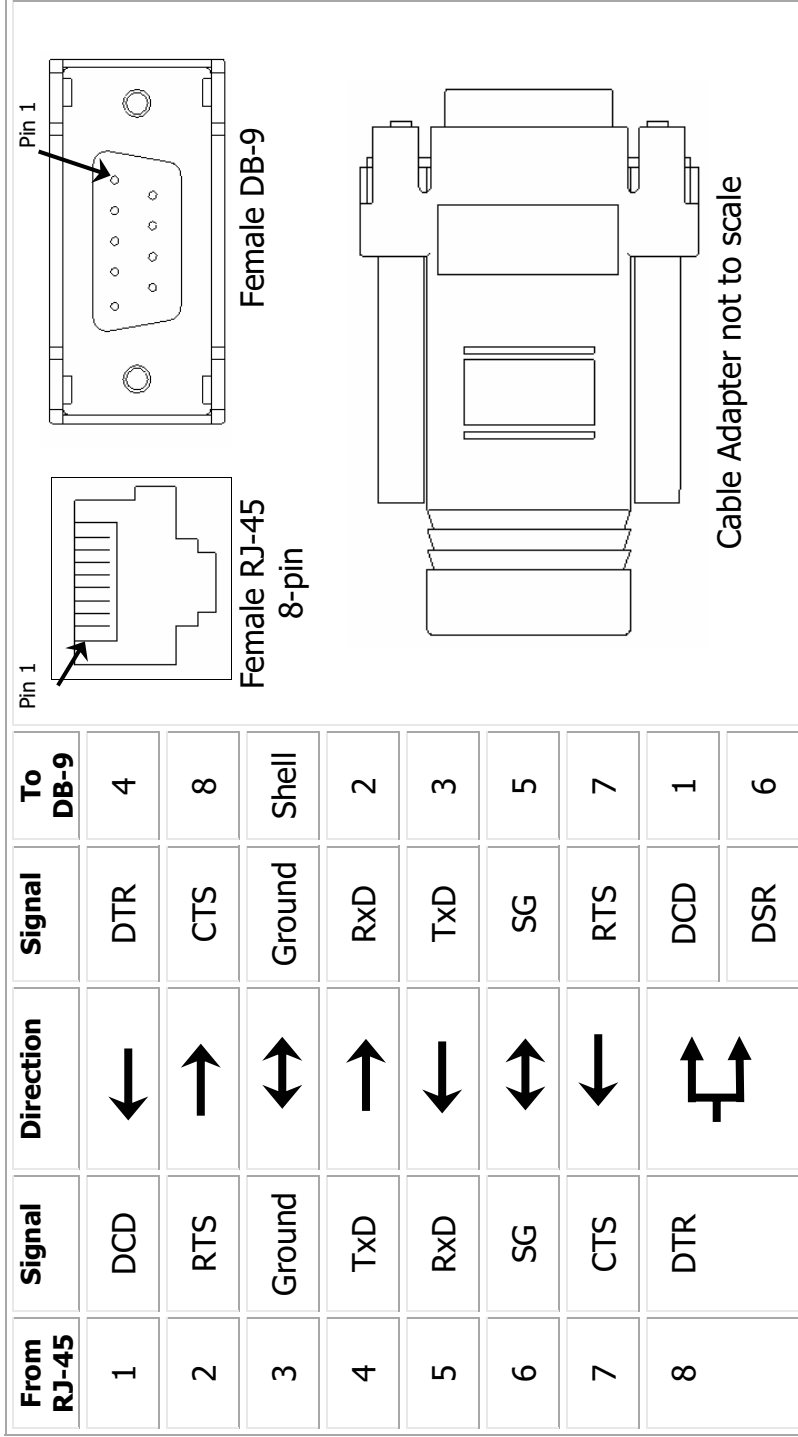

\* Arrows indicate which direction the signal is flowing

### Notes:

- All RJ45 cable adapters are 8-pin.
- Altpin should be turned on when using this cable adapter so that DTR will drive DCD (standard usage).
- If altpin is turned off, the hardware signal on RJ45 pin 1 becomes DSR instead of DCD. This alternative can be used if DCD is not required, and DSR is needed instead.
- This cable adapter utilizes the RTS signal of the serial device for hardware flow control (RTS/CTS).



# Digi One, PortServer TS, and Multi-Port Serial Cards RJ-45 to DB-25M Console Adapter

For use with Digi One TS, Portserver TS 2/4/8/16, and Multi-Port Serial Cards with RJ45 connectors

Digi Cable Adapters allow you to connect your serial devices using commercially available CAT 5 cable of any length. Simply plug standard CAT 5 cable into your Digi Product, connect a Cable Adapter to the other end and plug the adapter into your device.

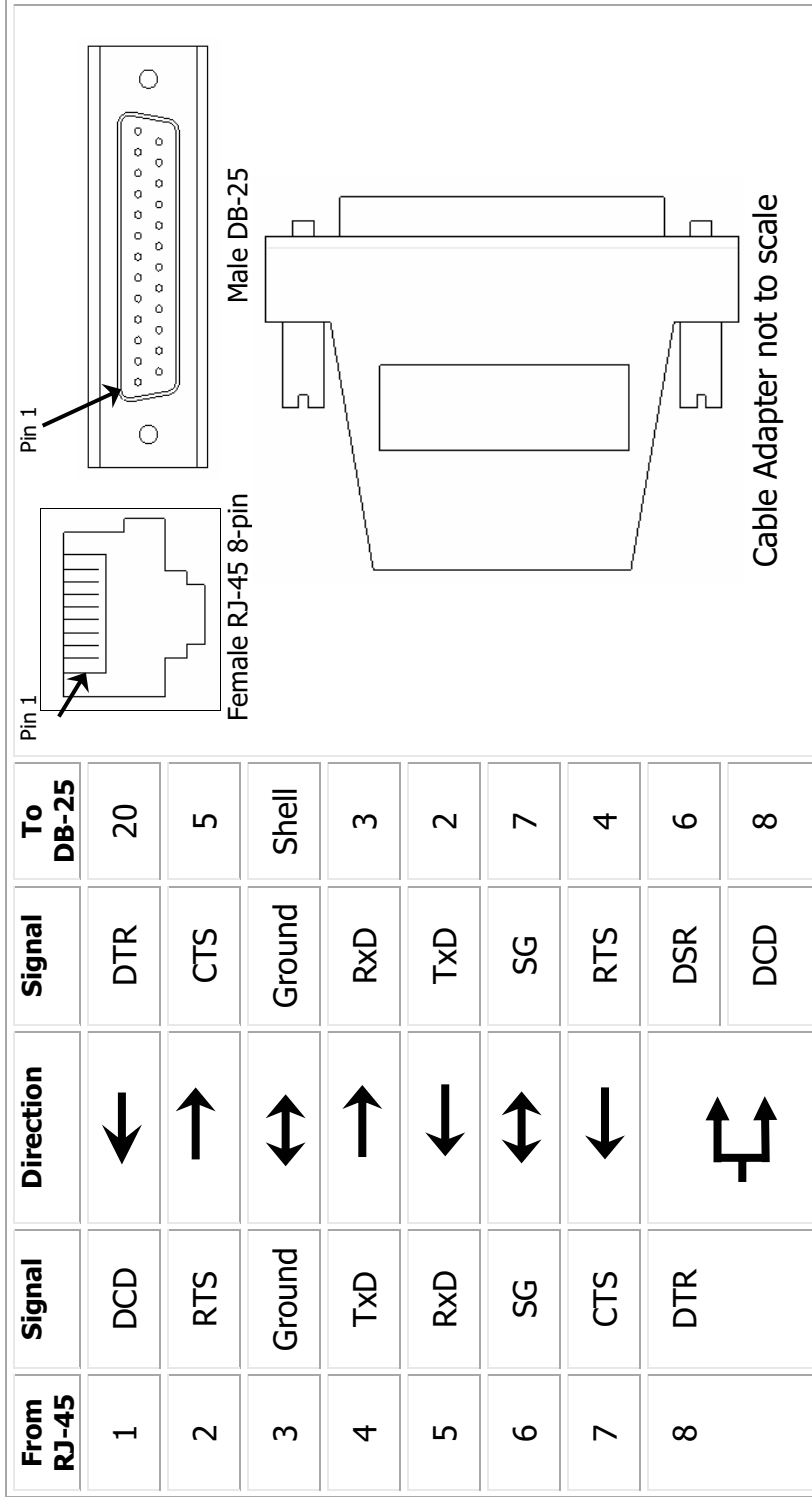

\* Arrows indicate which direction the signal is flowing

## Notes:

- All RJ45 cable adapters are 8-pin.
- Altpin should be turned on when using this cable adapter so that DTR will drive DCD (standard usage).
- If altpin is turned off, the hardware signal on RJ45 pin 1 becomes DSR instead of DCD. This alternative can be used if DCD is not required, and DSR is needed instead.
- This cable adapter utilizes the RTS signal of the serial device for hardware flow control (RTS/CTS).

## Cable Adapters

### Digi TS, RJ-45 to DB-25 Console Adapter

For use with Digi One TS, Portserver TS 2/4/8/16, and Multi-Port Serial Cards with RJ45 connectors

Digi Cable Adapters allow you to connect your serial devices using commercially available CAT 5 cable of any length. Simply plug standard CAT 5 cable into your Digi Product, connect a Cable Adapter to the other end and plug the adapter into your device.

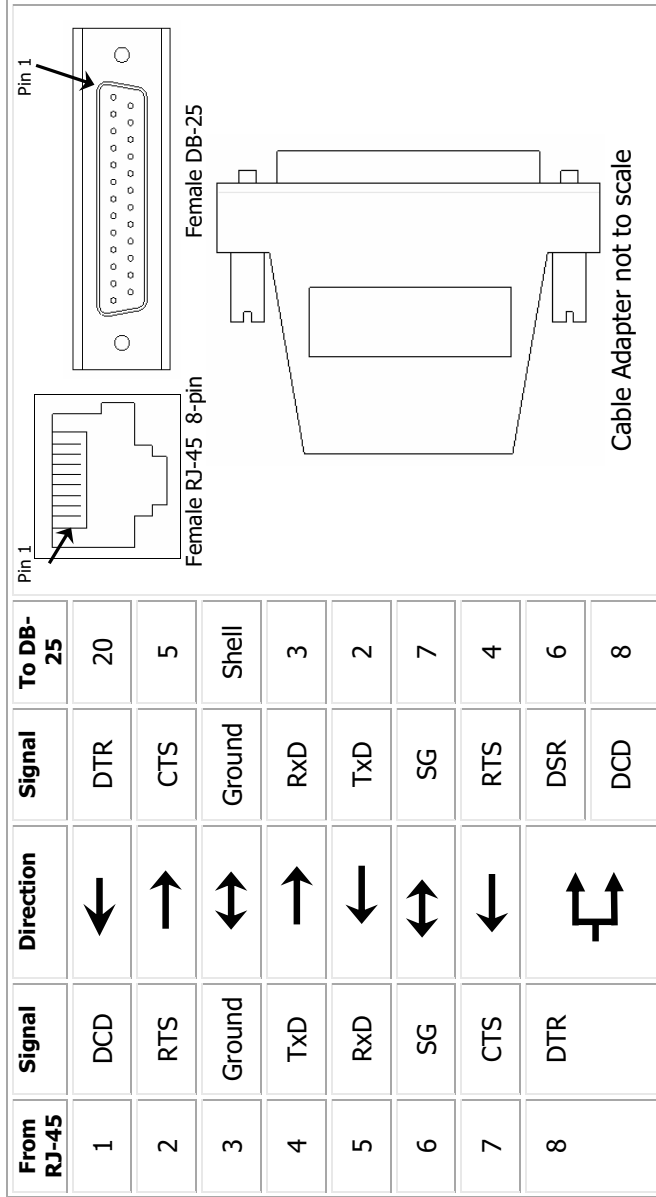

\* Arrows indicate which direction the signal is flowing

#### Notes:

- All RJ45 cable adapters are 8-pin.
- Alt pin should be turned on when using this cable adapter so that DTR will drive DCD (standard usage).
- If alt pin is turned off, the hardware signal on RJ45 pin 1 becomes DSR instead of DCD. This alternative can be used if DCD is not required, and DSR is needed instead.
- This cable adapter utilizes the RTS signal of the serial device for hardware flow control (RTS/CTS).

Digi Part Number 76000699

Digi TS DB25F Console Adapter (4-pack)

90000608\_A

## Digi TS, RJ-45 to DB-25 Modem Adapter

For use with Digi One TS, Portserver TS 2/4/8/16, and Multi-Port Serial Cards with RJ45 connectors

Digi Cable Adapters allow you to connect your serial devices using commercially available CAT 5 cable of any length. Simply plug standard CAT 5 cable into your Digi Product, connect a Cable Adapter to the other end and plug the adapter into your device.

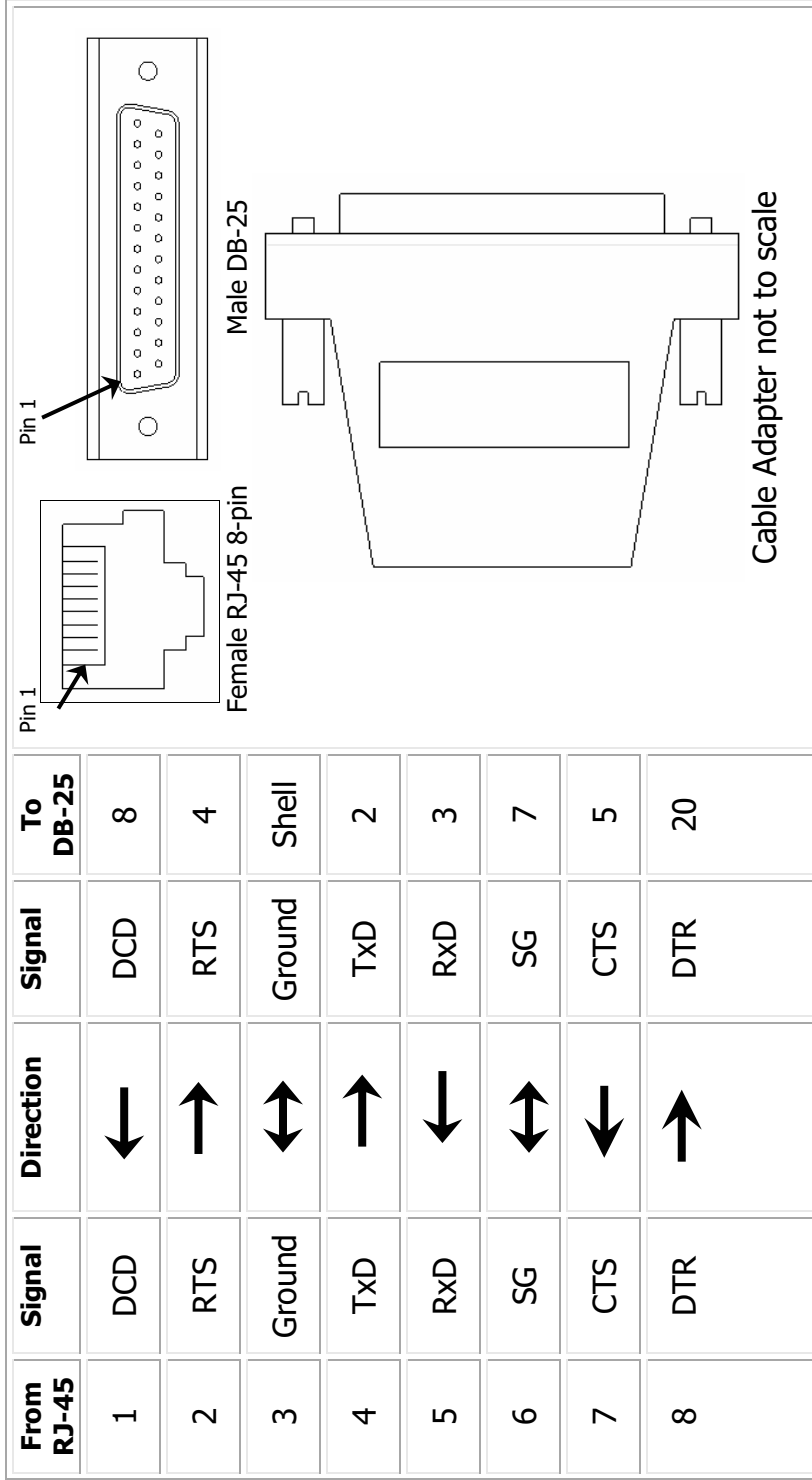

\* Arrows indicate which direction the signal is flowing

### Notes:

- All RJ45 cable adapters are 8-pin.
- When using this adapter with a modem or other applications that require DCD on pin 1, you must turn on altpin.
- If altpin is turned off, the hardware signal on pin 1 becomes DSR instead of DCD.
- This cable utilizes the CTS signal of the modem for hardware flow control (RTS/CTS).

Digi Part Number 76000700      Digi TS DB25M Modem Adapter (4-pack)

90000609\_A

# Digi TS, RJ-45 to DB-9 Modem Adapter

For use with Digi One TS, Portserver TS 2/4/8/16, and Multi-Port Serial Cards with RJ45 connectors

Digi Cable Adapters allow you to connect your serial devices using commercially available CAT 5 cable of any length. Simply plug standard CAT 5 cable into your Digi Product, connect a Cable Adapter to the other end and plug the adapter into your device.

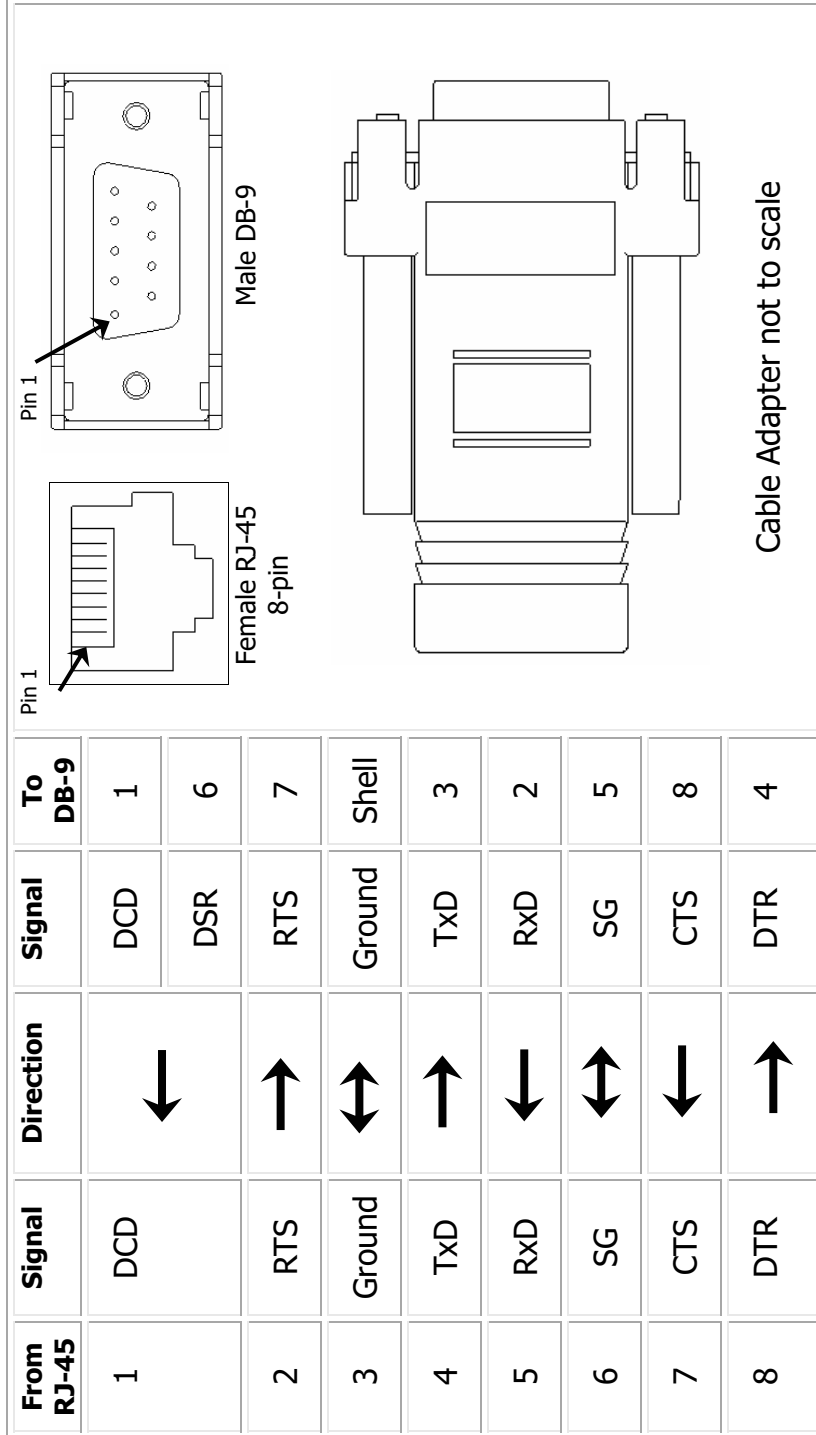

\* Arrows indicate which direction the signal is flowing

## Notes:

- All RJ45 cable adapters are 8-pin.
- When using this adapter with a modem or other applications that require DCD on pin 1, you must turn on altpin.
- If altpin is turned off, the hardware signal on pin 1 becomes DSR instead of DCD.
- This cable utilizes the CTS signal of the modem for hardware flow control (RTS/CTS).

Digi Part Number 76000701 Digi TS DB9M Modem Adapter (4-pack)

90000610\_A

# Digi One, PortServer TS, and Multi-Port Serial Cards RJ-45 to DB-25M Printer Adapter

## Cable Adapters

### Digi TS, RJ-45 to DB-25 Printer Adapter

For use with Digi One TS, Portserver TS 2/4/8/16, and Multi-Port Serial Cards with RJ45 connectors

Digi Cable Adapters allow you to connect your serial devices using commercially available CAT 5 cable of any length. Simply plug standard CAT 5 cable into your Digi Product, connect a Cable Adapter to the other end and plug the adapter into your device.

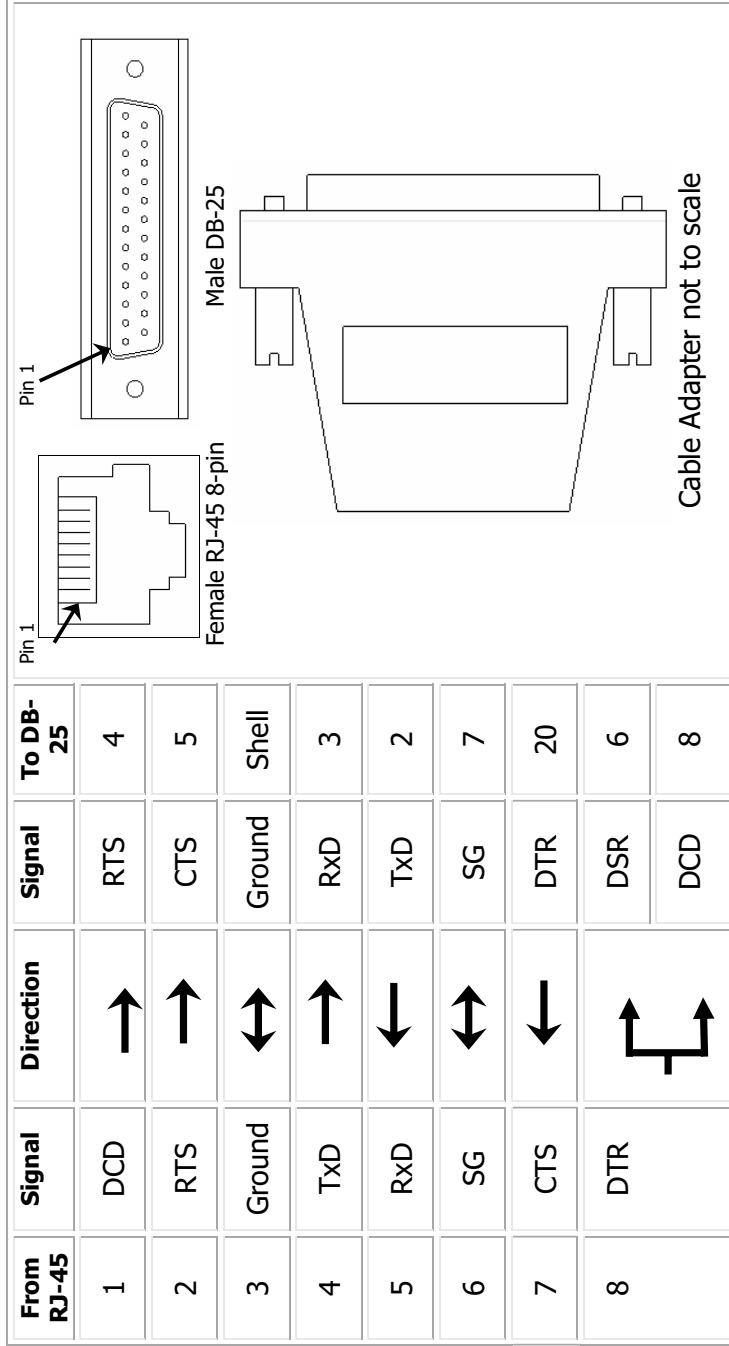

\* Arrows indicate which direction the signal is flowing

#### Notes:

- All RJ45 cable adapters are 8-pin.
- For use with Printers. This adapter utilizes the DTR signal of the serial device (instead of RTS) for hardware flow control (RTS/CTS)
- Okidata printers may use SSD (pin 11) instead of DTR (pin 20) on DB25 side of above diagram. If this is the case, the printer should be set to SSD+.
- Altpin should be turned on when using this cable so that DTR will drive DCD (standard usage).
- If altpin is turned off, the hardware signal on RJ45 pin 1 becomes DSR instead of DCD. This alternative can be used if DCD is not required, and DSR is needed instead.



# Digi CM RJ-45 to DB-9F DTE RS-232 Crossover Cable

## RJ45 to DB9 Female Crossover Cable

This cable will allow you to connect from the CM32 serial ports to console ports, terminals, printers and any other DTE RS232 device.

The wiring diagram is shown in Table 1.

**Table 1: EIA-232 RJ45 to DB-9**

From Port RJ45	Signal		Signal	To Port DB-9F
3	TxD	————	RxD	2
6	RxD	————	TxD	3
4	GND	————	GND	5
2	DTR		DSR	6
			DCD	1
8	DSR		DTR 4	
7	DCD			
1	RTS	————	CTS	8
5	CTS	————	RTS	7

FRONT:



RJ-45 8-Pin

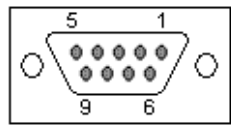

Female

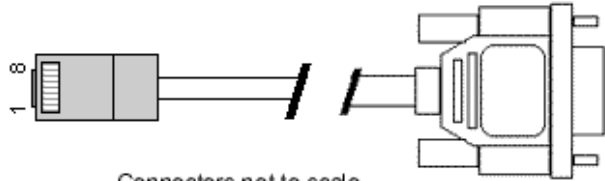

Connectors not to scale

# Digi CM RJ-45 to DB-25M Modem Adapter

## Cable Adapters

### Digi CM, RJ-45 to DB-25 Modem Adapter

For use with Digi CM 8, 16, 32, 48 – All Models

Digi Cable Adapters allow you to connect your serial devices using commercially available CAT 5 cable of any length. Simply plug standard CAT 5 cable into your Digi Product, connect a Cable Adapter to the other end and plug the adapter into your device.

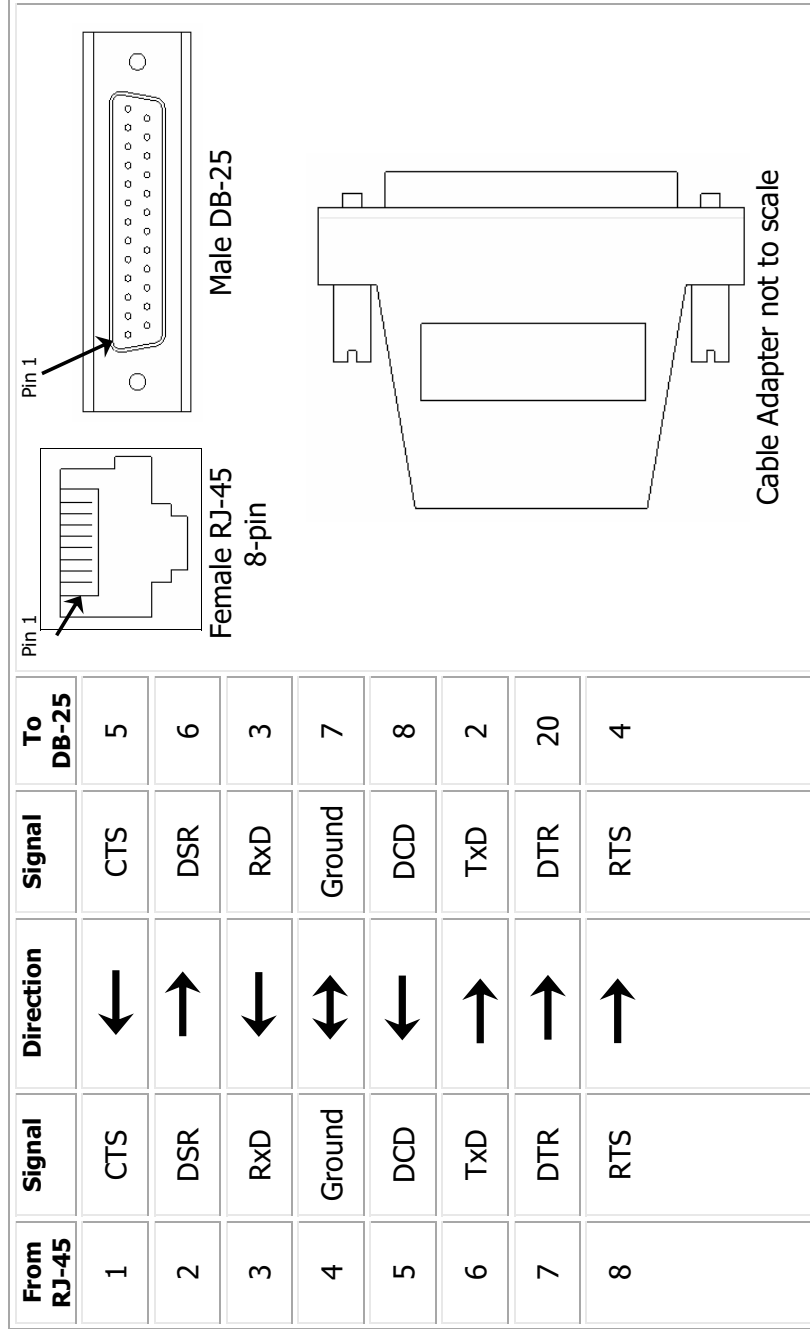

\* Arrows indicate which direction the signal is flowing

#### Notes:

- All RJ45 cable adapters are 8-pin.

Digi Part Number 76000670      Digi CM DB25M Modem Adapter (8-pack)

# Digi CM RJ-45 to DB-9F Console Adapter

## Cable Adapters

### Digi CM, RJ-45 to DB-9 Console Adapter

For use with Digi CM 8, 16, 32, 48 – All Models

Digi Cable Adapters allow you to connect your serial devices using commercially available CAT 5 cable of any length. Simply plug standard CAT 5 cable into your Digi Product, connect a Cable Adapter to the other end and plug the adapter into your device.

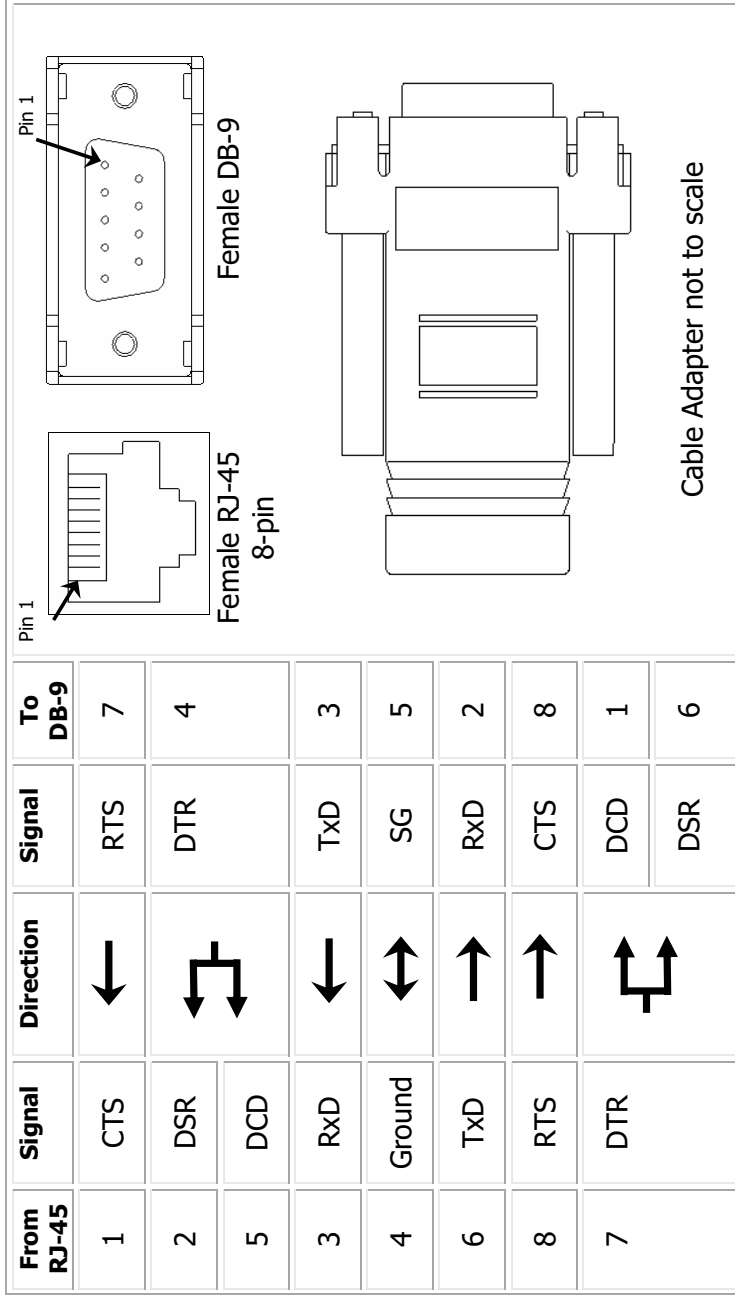

\* Arrows indicate which direction the signal is flowing

### Notes:

- All RJ45 cable adapters are 8-pin.

Digi Part Number 76000671 Digi CM DB9F Console Adapter (8-pack)



# Digi CM RJ-45 to DB-25M Console Adapter

## Cable Adapters

### Digi CM, RJ-45 to DB-25 Console Adapter

For use with Digi CM 8, 16, 32, 48 – All Models

Digi Cable Adapters allow you to connect your serial devices using commercially available CAT 5 cable of any length. Simply plug standard CAT 5 cable into your Digi Product, connect a Cable Adapter to the other end and plug the adapter into your device.

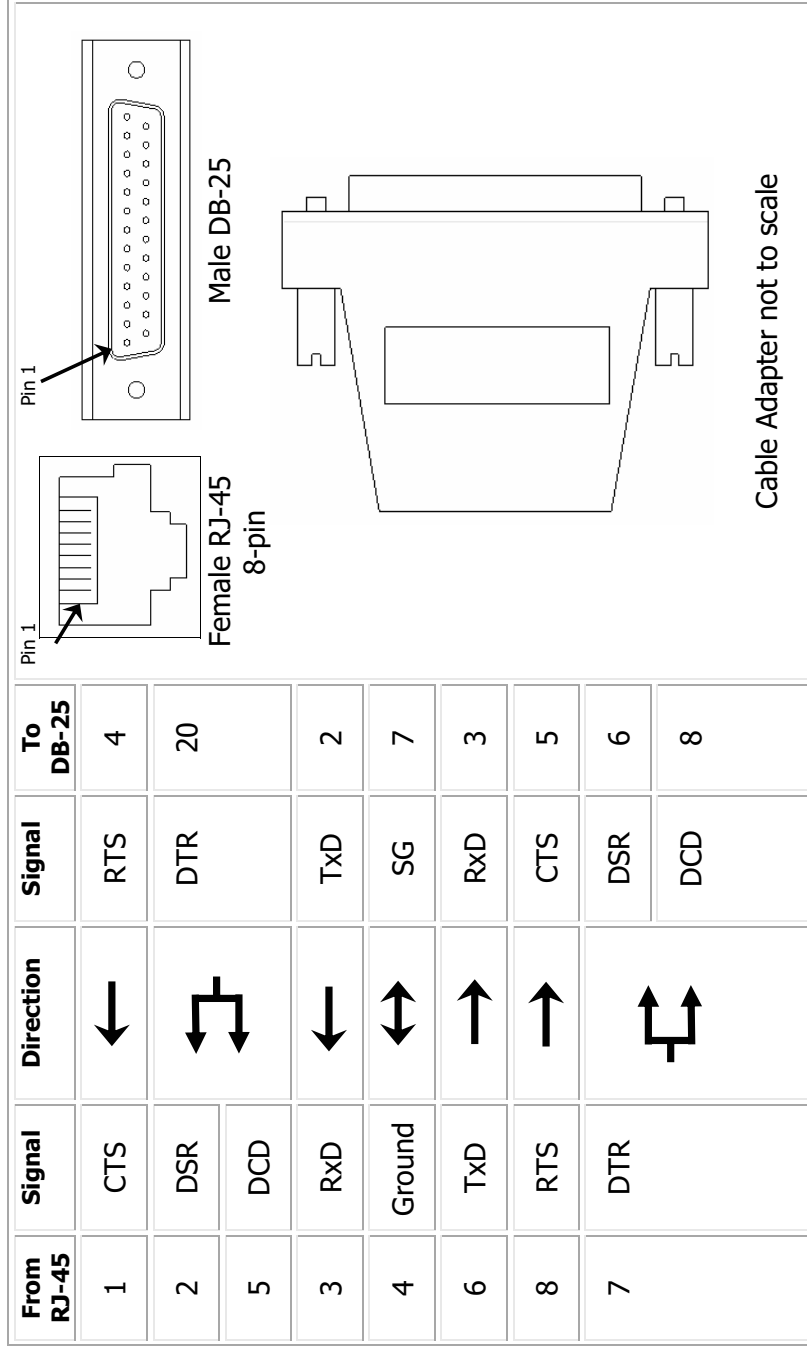

\* Arrows indicate which direction the signal is flowing

#### Notes:

- All RJ45 cable adapters are 8-pin.

Digi Part Number 76000672 Digi CM DB25M Console Adapter (8-pack)

90000614\_A

# Digi CM RJ-45 to DB-25F Console Adapter

## Cable Adapters

### Digi CM, RJ-45 to DB-25 Console Adapter

For use with Digi CM 8, 16, 32, 48 – All Models

Digi Cable Adapters allow you to connect your serial devices using commercially available CAT 5 cable of any length. Simply plug standard CAT 5 cable into your Digi Product, connect a Cable Adapter to the other end and plug the adapter into your device.

From RJ-45	Signal	Direction	Signal	To DB-25
1	CTS	←	RTS	4
2	DSR	↕	DTR	20
5	DCD			
3	RxD	←	TxD	2
4	Ground	↔	SG	7
6	TxD	→	RxD	3
8	RTS	→	CTS	5
7	DTR	↕	DSR	6
			DCD	8

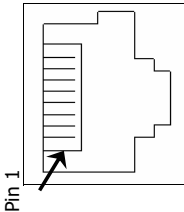

Female RJ-45  
8-pin

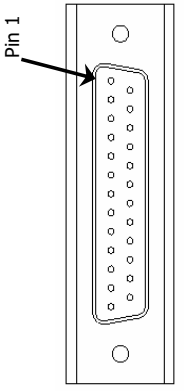

Female DB-25

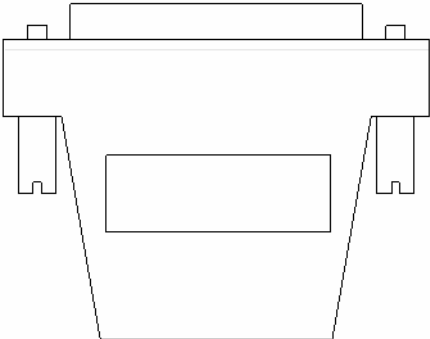

Cable Adapter not to scale

\* Arrows indicate which direction the signal is flowing

### Notes:

- All RJ45 cable adapters are 8-pin.

Digi Part Number 76000673 Digi CM DB25F Console Adapter (8-pack)

90000615\_A

# Digi CM RJ-45 to DB-9M Modem Adapter

## Cable Adapters

### Digi CM, RJ-45 to DB-9 Modem Adapter

For use with Digi CM 8, 16, 32, 48 – All Models

Digi Cable Adapters allow you to connect your serial devices using commercially available CAT 5 cable of any length. Simply plug standard CAT 5 cable into your Digi Product, connect a Cable Adapter to the other end and plug the adapter into your device.

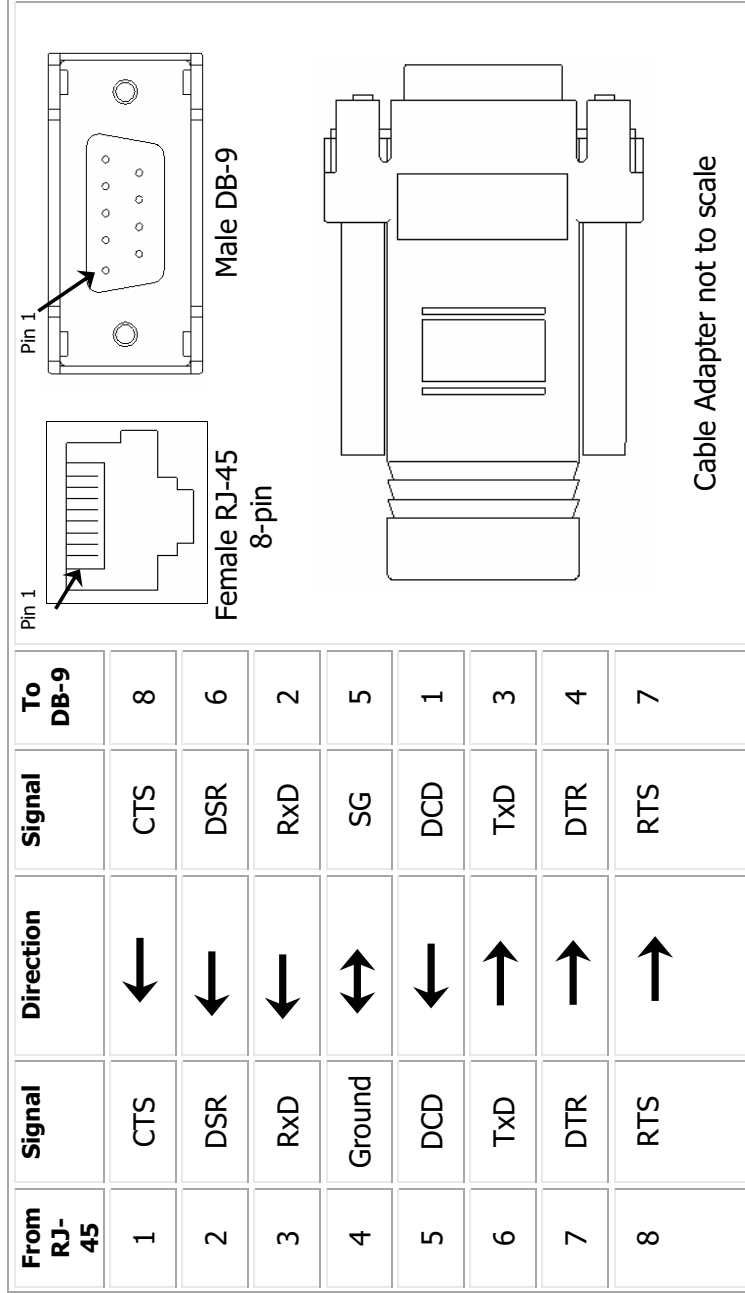

From RJ-45	Signal	Direction	Signal	To DB-9
1	CTS	←	CTS	8
2	DSR	←	DSR	6
3	RxD	←	RxD	2
4	Ground	↔	SG	5
5	DCD	←	DCD	1
6	TxD	→	TxD	3
7	DTR	→	DTR	4
8	RTS	→	RTS	7

\* Arrows indicate which direction the signal is flowing

#### Notes:

- All RJ45 cable adapters are 8-pin.

Digi Part Number 76000702      Digi CM DB9M Modem Adapter (8-pack)

# Digi CM RJ-45 to DB-25M (DCE RS 232) Straight-Through Cable

## RJ45 to DB25 Male Straight Through Cable

This cable will allow you to connect from the CM32 serial ports to modems and other DCE RS232 devices. The wiring diagram is shown in Table 1.

**Table 1: EIA-232 RJ45 to DB-25**

From Port RJ45	Signal	Signal	To Port DB-25M
3	TxD	TxD	2
6	RxD	RxD	3
4	GND	GND	7
2	DTR	DTR	20
8	DSR	DSR	6
7	DCD	DCD	8
1	RTS	RTS	4
5	CTS	CTS	5

FRONT:



RJ-45 8-Pin

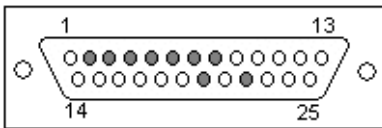

Male DB-25

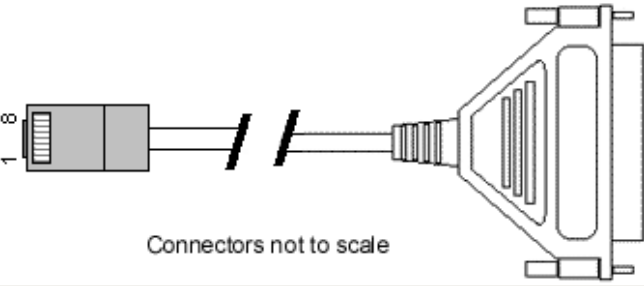

Connectors not to scale

# Digi CM RJ-45 to DB-25M (DTE RS 232) Crossover Cable

## RJ45 to DB25 Female/Male Crossover Cable

This cable will allow you to connect from the CM32 serial ports to console ports, terminals, printers and any other DTE RS232 device.

The wiring diagram is shown in Table 1.

**Table 1: EIA-232 RJ45 to DB-25**

From Port RJ45	Signal		Signal	To Port DB-25F/M
3	TxD	————	RxD	3
6	RxD	————	TxD	2
4	GND	————	GND	7
2	DTR	↔	DSR	6
			DCD	8
8	DSR	↔	DTR	20
7	DCD			
1	RTS	————	CTS	5
5	CTS	————	RTS	4

FRONT: 

RJ-45 8-Pin

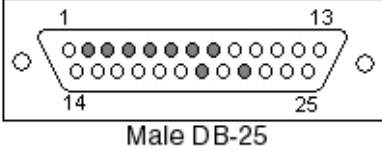

Male DB-25

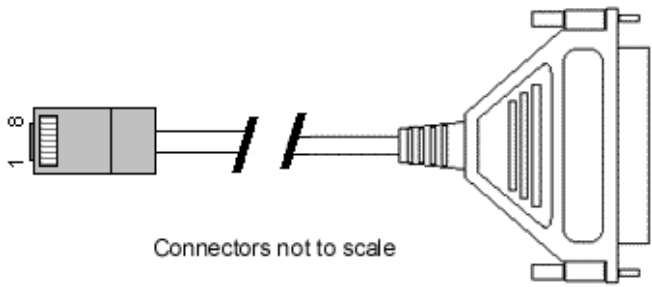

# Digi CM RJ-45 to RJ-45 Sun Netra or Cisco Crossover Cable

## RJ45 to Sun Netra/Cisco RJ45 Crossover Cable

This cable will allow you to connect to a Sun Netra server or a Cisco product. The wiring diagram is shown in Table 1.

**Table 1: EIA-232 RJ45 to RJ45**

From Port RJ45	Signal		Signal	To Port RJ45 Netra Cisco
3	TxD	————	RxD	6
6	RxD	————	TxD	3
4	GND	————	GND	4
2	DTR	————	DSR	7
7	DCD	————	DTR	2
1	RTS	————	CTS	8
5	CTS	————	RTS	1

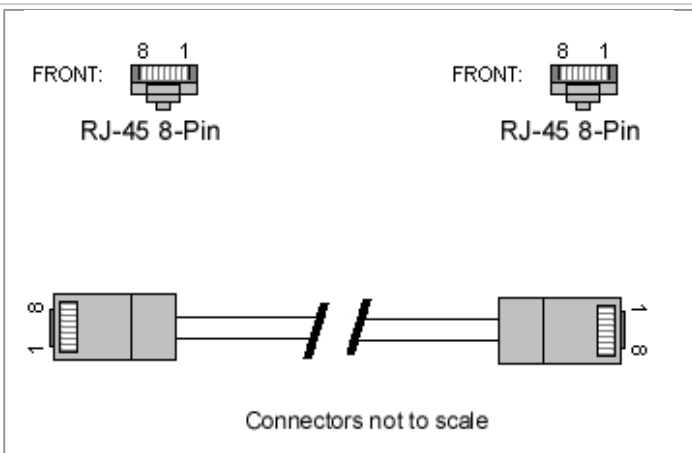

# Digi CM RJ-45 to Sun Mini Din Cable

## Digi CM RJ45 to Sun Mini Din 8-Pin

The Digi CM uses an RJ45 connector for serial ports. The pin assignment of the RJ45 connector for serial ports is summarized in table 2 below. Each pin has a function according to the serial communication type configuration.

The Sun Mini Din 8-Pin wiring diagram is shown in Table 1.

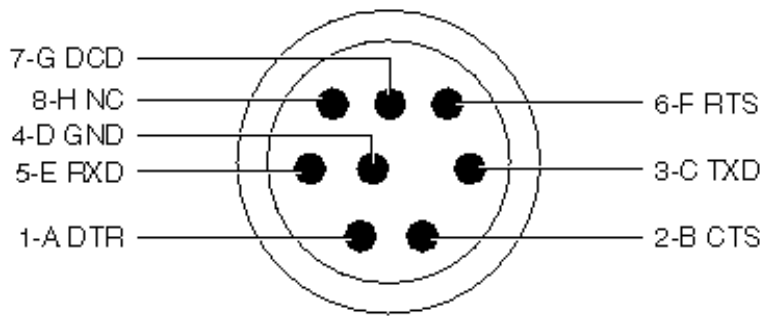
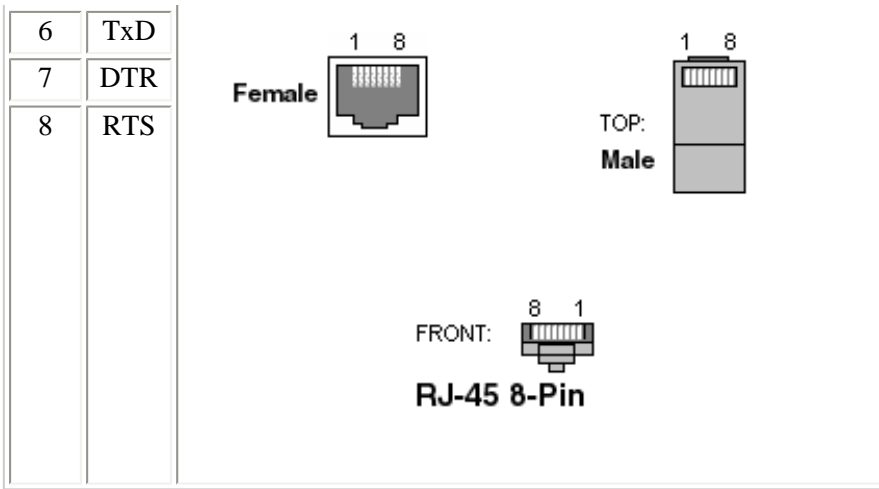

TABLE A-18 Serial Mini Din 8-pin Connector Pinouts

Pin	Signal Name	Pin	Signal Name
1	FP_SER_A_DTR	5	FP_SER_A_RXD
2	FP_SER_A_CTS	6	FP_SER_A_RTS
3	FP_SER_A_TXD	7	FP_SER_A_DCD
4	FP_SER_A_GND	8	GND

The Digi CM wiring diagram is shown in Table 2.

Digi CM RJ45	Signal
1	CTS
2	DSR
3	RxD
4	GND
5	DCD*









**NOTE:** inbound signal can also be used as a second ground



# Async Conversion RJ-XX to DB-XX

## IEA 232 Conversion Chart: Acceleport, Etherlite, and PortServer Families

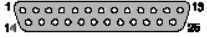
### Acceleport, Etherlite, and PortServer Families RJXX to DBXX Conversion Sheet

RJ- 11 4-pin	RJ-11 6-pin	RJ-45 8-pin	RJ-45 10-pin	EtherLite 8-pin	Signal Name	DB-25 (Male)	DB-9 (Male)
							
			1-----		RI	-----22	-----9
		1-----	2-----	2-----	DSR	-----6	-----6
	1-----	2-----	3-----	1-----	RTS	-----4	-----7
	2-----	3-----	4-----	-none-	GND	-----Shell	----Shell
1-----	3-----	4-----	5-----	5-----	TxD	-----2	-----3
2-----	4-----	5-----	6-----	4-----	RxD	-----3	-----2
3-----	5-----	6-----	7-----	6-----	SG	-----7	-----5
4-----	6-----	7-----	8-----	8-----	CTS	-----5	-----8
	7-----	8-----	9-----	7-----	DTR	-----20	-----4
	8-----	9-----	10-----	3-----	DCD	-----8	-----1

DCE		DTE
Output-----	RI	-----Input
Output-----	DSR	-----Input

Input-----	RTS	-----Output
Chassis Ground-	GND	-----Chassis Ground
Input-----	TxD	-----Output
Output-----	RxD	-----Input
Signal Ground--	SG	-----Signal Ground
Output-----	CTS	-----Input
Input-----	DTR	-----Output
Output-----	DCD	-----Input

## Cable Vendors

### Recommended Custom Cable Vendors

Below are our recommended cable vendors to make or extend the length of cables

**The Whyte haus**  
260-484-5666  
[the.whytehaus@verizon.net](mailto:the.whytehaus@verizon.net)

**DataCable Technologies**  
630-226-5600  
[r.j@datacabletech.com](mailto:r.j@datacabletech.com)  
Contact: RJ Clabots

**Predator Grizzly Cable**  
503-292-7151 x1101

**Black Box**  
800-231-3222

**Control Cable Inc.**  
800-296-4411  
[sales@controlcable.com](mailto:sales@controlcable.com)  
Contact: Valerie Hoffman

## DataFire Sync 2000 SCSI Pinouts

### DataFire SYNC 2000 Cables

### DataFire SYNC 2000 SCSI Connector Pinout

<u>SIGNAL</u>	<u>SCSI J1</u>	<u>SCSI J2</u>	<u>NOTES</u>
ID0	1	--	OPEN
ID1	35	--	OPEN
ID2	2	--	OPEN
ID3	36	--	TIED TO SHELL ON 68 PIN END
GND	SHELL	SHELL,A,B	USE BRAID TO CONNECT SHELLS
103B TxD+	4	S	TWISTED PAIR
103A TxD-	38	P	
113B TxCLKo+	5	W	TWISTED PAIR
113A TxCLKo-	39	U	
105B RTS+	6		
105A RTS-	40		
108B DTR+	7		
108A DTR -	41		
104B RxD+	8	T	TWISTED PAIR
104A TxD-	42	R	
115B RxCLKi+	43	X	TWISTED PAIR
115A RxCLKi-	9	V	
114B TxCLKi+	10	AA	TWISTED PAIR
114A TxCLKi-	44	Y	
106B CTS+	11		
106A CTS-	45		
107B DSR+	12		
107A DSR-	46		
109B DCD+	13		
109A DCD-	47		
107 DSR	14	E	TWISTED PAIR
109 DCD	48	F	
105 RTS	16	C	TWISTED PAIR
108 DTR	50	H	
106 CTS	52	D	TWISTED PAIR
GND	SHELL	SHELL	

# Digi One EM DB-9 Connector Pinouts

## DB

# Digi One EM

The wiring diagram for the DB-9 connector is shown in Table 1.

Table 1: DB-9 connector

DB-9	Direction	Signal
1	←	DCD
2	←	RxD
3	→	TxD
4	→	DTR
5	↔	SG
6	←	DSR
7	→	RTS
8	←	CTS
9	←	RI

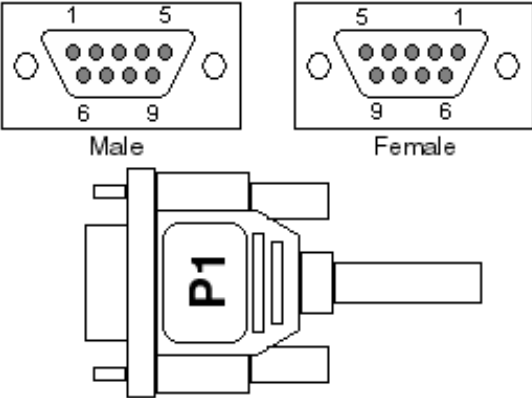

The diagram shows three types of connectors. At the top, there are two DB-9 connectors: a Male connector with pins numbered 1, 5, 6, and 9, and a Female connector with pins numbered 5, 1, 9, and 6. Below these is a P1 port connector, which is a D-subminiature connector with a central pin and a label 'P1' on its side.

# Digi One IA RealPort DB-9 Connector Pinout

## DIGI ONE REALPORT IA EIA-232 PINOUTS

The wiring diagram for the EIA-232 DB-9 connector is shown in Table 1 and the Terminal Block in Table 2.

**Table 1: DB-9 connector**

DB-9	Direction	Signal
1	←	DCD
2	←	RxD
3	→	TxD
4	→	DTR
5	↔	SG
6	←	DSR
7	→	RTS
8	←	CTS
9	←	RI

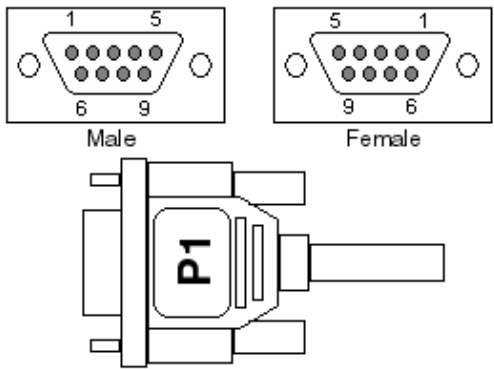

**Table 2: Terminal Block**

DB-9	Direction	Signal
1	←	DCD
2	←	RxD
3	→	TxD
4	→	DTR
5	↔	SG
6	←	DSR
7	→	RTS
8	←	CTS
9	←	RI

# Digi One EM DB-9 and Terminal Block Pinout

**Table 1: DB-9 connector**

DB-9	Direction	Signal
1	←	DCD
2	←	RxD
3	→	TxD
4	→	DTR
5	↔	SG
6	←	DSR
7	→	RTS
8	←	CTS
9	←	RI

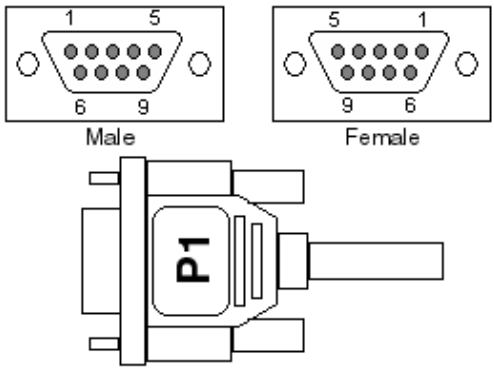

The diagram shows a Male DB-9 connector with pins numbered 1, 5, 6, and 9. The Female DB-9 connector has pins numbered 5, 1, 9, and 6. Below these is a 3D perspective view of a terminal block labeled 'P1' with a single pin extending from its right side.

**Table 2: Terminal Block**

DB-9	Direction	Signal
1	←	DCD
2	←	RxD
3	→	TxD
4	→	DTR
5	↔	SG
6	←	DSR
7	→	RTS
8	←	CTS
9	←	RI

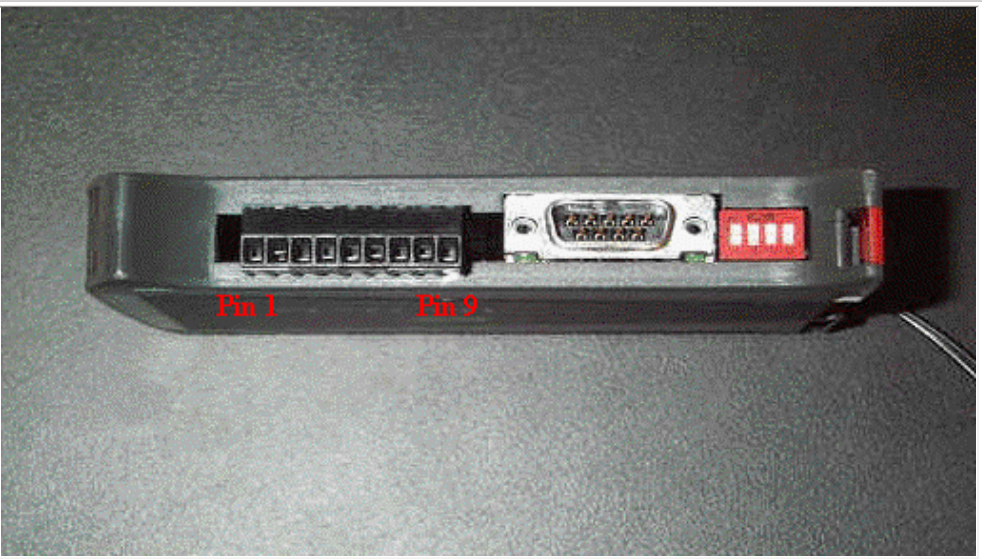

The photograph shows a grey terminal block with a DB-9 connector on the left and a red terminal block on the right. Red text labels 'Pin 1' and 'Pin 9' are placed below the terminal block to indicate the signal lines for pins 1 and 9.

Digi One SP DB-9 Pinout

# DIGI ONE SINGLE PORT PINOUT

The wiring diagram for the DB-9 connector is shown in Table 1.

**Table 1: DB-9 connector**

DB-9	Direction	Signal
1	←	DCD
2	←	RxD
3	→	TxD
4	→	DTR
5	↔	SG
6	←	DSR
7	→	RTS
8	←	CTS
9	←	RI

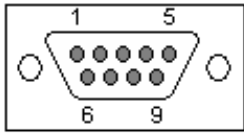

Male

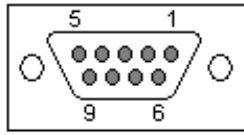

Female

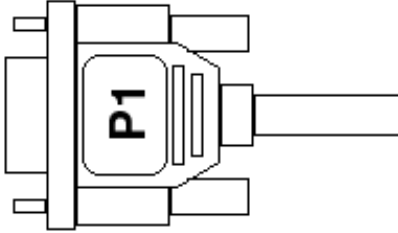

# Async EIA-422 DB-9 Connector Pinout

## DB 9 EIA422 Pinouts

### DB-9 Pinout Asynchronous EIA-422

The wiring diagram for an EIA-422 DB-9 connector is shown in Table 1.

Table 1: EIA-422 DB-9 connector

DB-9	Direction	Signal
2	→	RTS+
3	→	RTS-
4	←	CTS+
5	←	CTS-
6	←	RxD+
7	←	RxD-
8	→	TxD+
9	→	TxD-
Shell	↔	GND

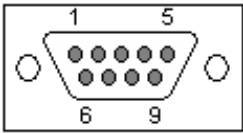

Male

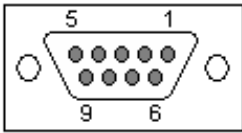

Female

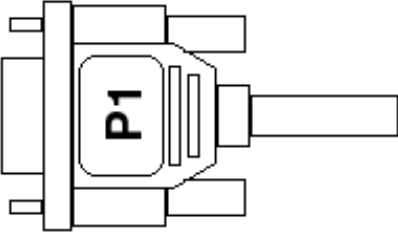



**Async EIA-422 DB-25 Pinout**

**DB**

**DB-25 Pinout, Asynchronous EIA-422**

EIA-422 Boards with DB-25 cable connectors

The wiring diagram for an EIA-422 DB-25 connector is shown in Table 1.

Table 1: EIA-422 DB-25 connector

DB-25	Direction	Signal
2	→	TxD+
14	→	TxD-
3	←	RxD+
16	←	RxD-
4	→	RTS+
19	→	RTS-
5	←	CTS+
13	←	CTS-
Shell	↔	GND

\* Arrows indicate which direction the signal is flowing

## Async RJ-45 to RJ-45 Crossover Cable

### Digi RJ45 8-pin to Digi RJ45 8-pin Crossover

# Digi RJ-45 8-pin to Digi RJ-45 8-pin Crossover Cable

## For Cross-Connecting Digi Asynchronous Ports Together

Table 1: Digi RJ-45 8-pin to Digi RJ-45 8-pin Crossover Cable

From RJ-45 Digi	Signal	Direction	Signal	To RJ-45 Digi
1	DSR	←	DTR	8
5	RxD	←	TxD	4
4	TxD	→	RxD	5
8	DTR	→	DSR	1
6	SG	↔	SG	6
2	RTS	→	CTS	7
7	CTS	←	RTS	2

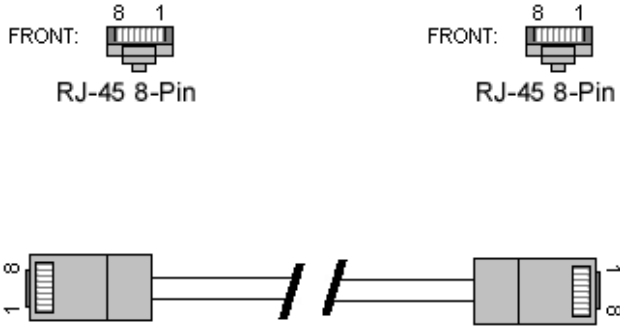

- Arrows indicate which direction the signal is flowing

# DB-25F to RJ-45 Cisco Console Cable Adapter

## Adapter Cables

### Digi EIA-232 - Cisco Console Adapter, DB-25 to RJ-45

The wiring diagram for a DB-25 to Cisco Console RJ-45 8-pin adapter cable is shown in Table 1.

Table 1: EIA-232 DB-25 to RJ-45

From DB-25	Signal	Direction	Signal	To RJ-45
8	DCD	←	DTR	2
3	RxD	←	TxD	3
2	TxD	→	RxD	6
20	DTR	→	DSR	7
7	SG	↔	SG	5
4	RTS	→	CTS	8
5	CTS	←	RTS	1
1	GND	↔	GND	4

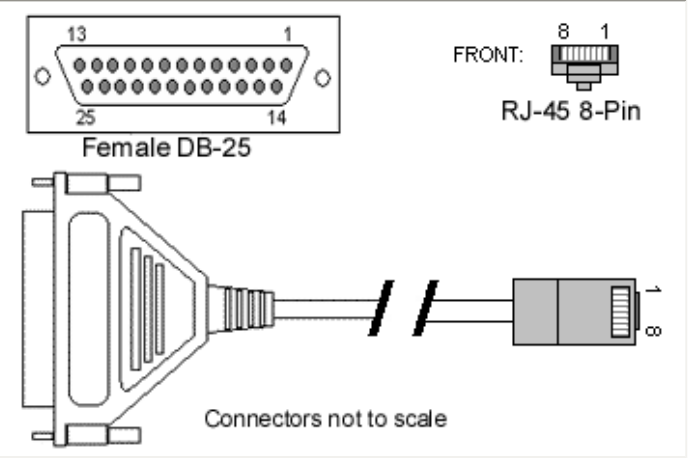

Female DB-25

FRONT: 8 1  
RJ-45 8-Pin

Connectors not to scale

- Arrows indicate which direction the signal is flowing

#### NOTES:

- Works for most current Cisco routers.
- Altpin should be turned off when using this cable.

# SCSI Terminal Server DB-25M to RJ-45 Cisco Console Cable Adapter

## Modem Cables

### Digi - Cisco Console Adapter, DB-25 to RJ-45

EIA-232 Boards which require DB-25 Male Cables Assemblies - SCSI Terminal Server ST1002, SCSI Terminal Server ST1008, SCSI Terminal Server ST1016, SCSI Terminal Server ST1600

The wiring diagram for a DB-25 to Cisco Console RJ-45 8-pin adapter cable is shown in Table 1.

Table 1: EIA-232 DB-25 to RJ-45

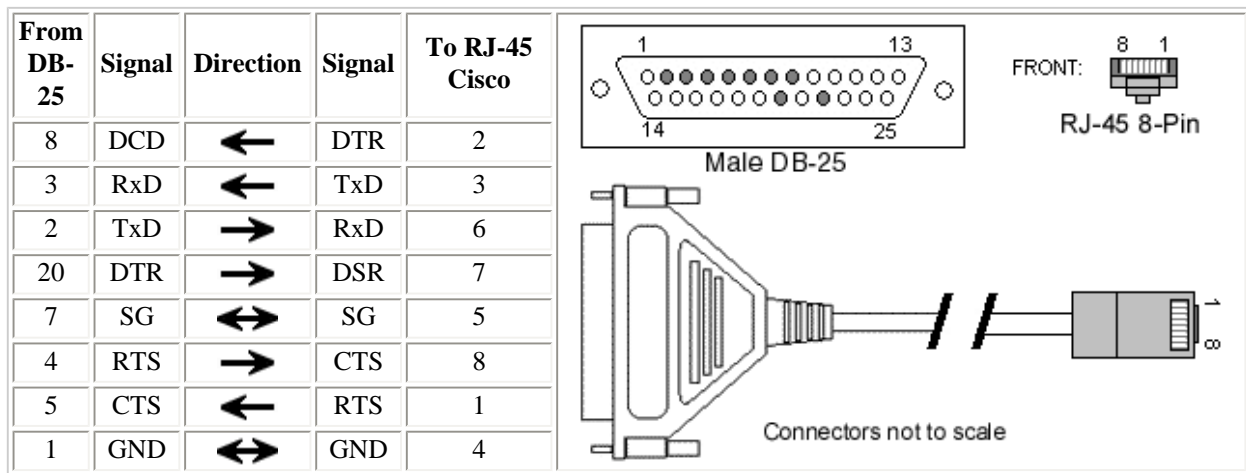

- Arrows indicate which direction the signal is flowing

## Difference Between DTE and DCE

### DTE vs. DCE

This is one of the most misunderstood areas of RS-232. DTE stands for Data Terminal Equipment, and DCE stands for Data Communications Equipment. DTE is typically either a dumb terminal or the serial port on a computer/workstation. DCE is typically a modem, DSU/CSU, or other piece of data communications equipment, hence the names. This is all most people really need to know about these terms.

Where it gets confusing is when you start to talk about signal definitions and direction. For example, it's easy for someone to understand that when you transmit data, you send it out. However, when you talk in terms of DCE, it becomes an input signal. This is because the specification was written from the perspective of the DTE end of the link. Another example is the Receive Data signal is an input to DTE, but an output from DCE.

Therefore, a straight through "one to one" cable is all that is necessary between a modem and a standard DTE serial port. However, if you want to connect two DTE ports together, you have to simulate the existence of the pair of DCE devices, typically modems that would normally be between the two DTE devices. This is where the null-modem device or cable comes in.

# DB-9F to RJ-45 3 COM Total Control/COMPAQ Microcom Modem Cable

## Modem Cables

### EIA-232 Modem Cables, DB-9 to RJ-45 8-pin

The wiring diagram for a DB-9 pin to 3COM Total Control RJ-45 8-pin/Compaq Microcom RJ-45 8-pin modem cable is shown in Table 1.

**Table 1: EIA-232 DB-9 to RJ-45 8-pin**

DB-9	Signal	Direction	Signal	To RJ-45
1	DCD	←	DCD	2
2	RxD	←	RxD	5
3	TxD	→	TxD	6
4	DTR	→	DTR	3
5	SG	↔	SG	4
6	DSR	←	DSR	N/A
7	RTS	→	RTS	8
8	CTS	←	CTS	7
9	RI	←	RI	1
Shell	GND	↔	GND	N/A

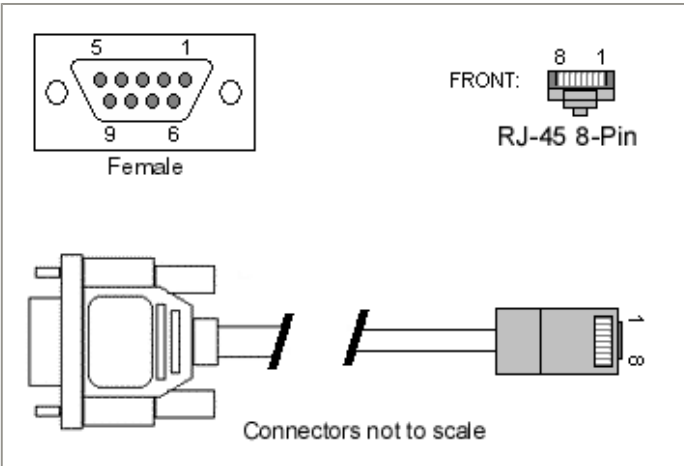

- Arrows indicate which direction the signal is flowing

#### NOTES:

- Altpin should be turned off when using this cable.

# SCSI Terminal Server DB-25M to RJ-45 3 COM Total Control/COMPAQ Microcom Modem Cable

## Modem Cables

### Modem Cables, DB-25 to RJ-45

EIA-232 Boards which require DB-25 Male Cables Assemblies - SCSI Terminal Server ST1002, SCSI Terminal Server ST1008, SCSI Terminal Server ST1016, SCSI Terminal Server ST1600

The wiring diagram for a DB-25 pin to 3COM Total Control/COMPAQ Microcom rj-45 8-pin modem cable is shown in Table 1.

Table 1: EIA-232 DB-25 to RJ-45

From DB-25	Signal	Direction	Signal	To RJ-45
8	DCD	←	DCD	2
3	RxD	←	RxD	5
2	TxD	→	TxD	6
20	DTR	→	DTR	3
7	SG	↔	SG	4
6	DSR	←	DSR	N/A
4	RTS	→	RTS	8
5	CTS	←	CTS	7
22	RI	←	RI	1
Shell	GND	↔	GND	N/A

- Arrows indicate which direction the signal is flowing

# DB-25F to RJ-45 3 COM Total Control/COMPAQ Microcom Modem Cable

## Modem Cables

### EIA-232 Modem Cables, DB-25 to RJ-45

The wiring diagram for a DB-25 pin to 3COM Total Control/COMPAQ Microcom RJ-45 8-pin modem cable is shown in Table 1.

**Table 1: EIA-232 DB-25 to RJ-45**

From DB-25	Signal	Direction	Signal	To RJ-45
8	DCD	←	DCD	2
3	RxD	←	RxD	5
2	TxD	→	TxD	6
20	DTR	→	DTR	3
7	SG	↔	SG	4
6	DSR	←	DSR	N/A
4	RTS	→	RTS	8
5	CTS	←	CTS	7
22	RI	←	RI	1
Shell	GND	↔	GND	N/A

- Arrows indicate which direction the signal is flowing

**NOTES:**

- Altpin should be turned off when using this cable.



# RJ-45 to RJ-45 (Altpin On) 3 COM Total Control/COMPAQ Microcom Modem Cable

## Modem Cables

### EIA-232 Modem Cables, RJ-45 to RJ-45

The wiring diagram for a RJ-45 8-pin to 3COM Total Control/Compaq Microcom RJ-45 8-pin modem cable is shown in Table 1.

**Table 1: EIA-232 Altpin RJ-45 to RJ-45**

From RJ-45	Signal	Direction	Signal	To RJ-45
1	DCD	←	DCD	2
5	RxD	←	RxD	5
4	TxD	→	TxD	6
8	DTR	→	DTR	3
6	SG	↔	SG	4
2	RTS	→	RTS	8
7	CTS	←	CTS	7

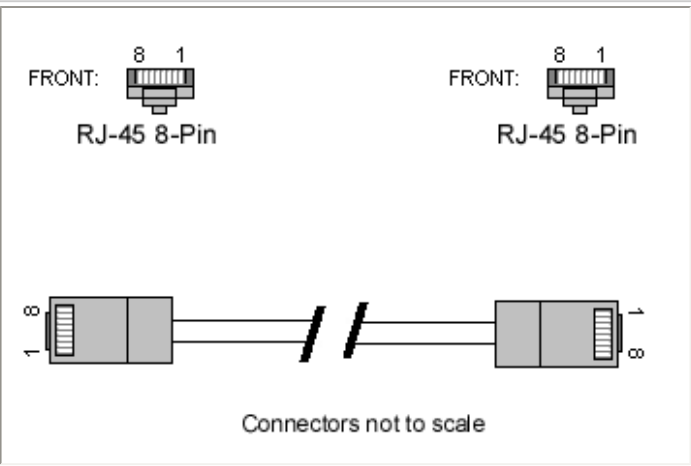

- Arrows indicate which direction the signal is flowing

#### NOTES:

- Altpin should be turned on when using this cable.

# RJ-45 10 Pin to RJ-45 3 COM Total Control/Compaq Microcom Modem Cable

## Modem Cables

### EIA-232 Modem Cables, RJ-45 to RJ-45 8-pin

The wiring diagram for a RJ-45 10-pin to 3COM Total Control/Compaq Microcom RJ-45 8-pin pin modem cable is shown in Table 1.

**Table 1: EIA-232 RJ-45 10-pin to RJ-45 8-pin**

From RJ-45	Signal	Direction	Signal	To RJ-45
10	DCD	←	DCD	2
6	RxD	←	RxD	5
5	TxD	→	TxD	6
9	DTR	→	DTR	3
7	SG	↔	SG	4
2	DSR	←	DSR	N/A
3	RTS	→	RTS	8
8	CTS	←	CTS	7
1	RI	←	RI	1
Shell	GND	↔	GND	Shell

- Arrows indicate which direction the signal is flowing

#### NOTES:

- If using this cable with RAS under Windows issue `ATS58=1&w` to the modem.
- Altpin should be turned off when using this cable.

# DB-9F to DB-9M Modem Cable

## Modem Cables

### EIA-232 Modem Cables DB-9 to DB-9

The wiring diagram for a DB-9 to DB-9 modem cable is shown in Table 1.

Table 1: EIA-232 DB-9 to DB-9 modem cable

DB-9	Signal	Direction	Signal	To DB-9
1	DCD	←	DCD	1
2	RxD	←	RxD	2
3	TxD	→	TxD	3
4	DTR	→	DTR	4
5	SG	↔	SG	5
6	DSR	←	DSR	6
7	RTS	→	RTS	7
8	CTS	←	CTS	8
9	RI	←	RI	9
Shell	GND	↔	GND	Shell

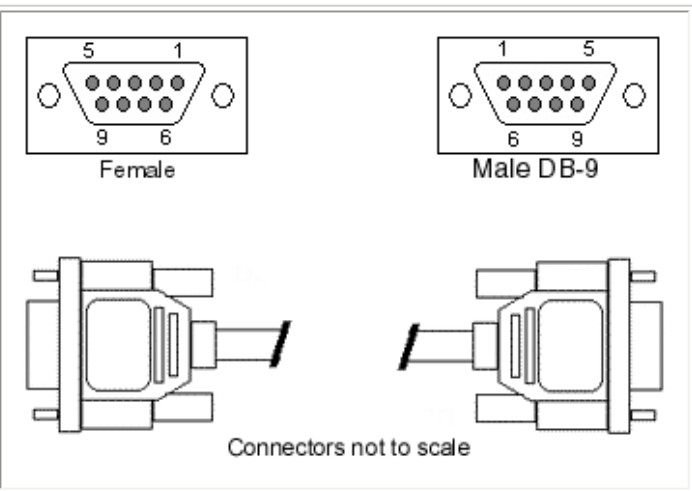

\* Arrows indicate which direction the signal is flowing

#### NOTES:

- Altpin should be turned off when using this cable.
- This cable utilizes the CTS signal of the modem for hardware flow control (RTS/CTS).

# DB-9F to DB-25M Modem Cable

## Modem Cables

### EIA-232 Modem Cables DB-9 to DB-25

The wiring diagram for a DB-9 to DB-25 modem cable is shown in Table 1.

**Table 1: EIA-232 DB-9 to DB-25 modem cable**

DB-9	Signal	Direction	Signal	To DB-25
1	DCD	←	DCD	8
2	RxD	←	RxD	3
3	TxD	→	TxD	2
4	DTR	→	DTR	20
5	SG	↔	SG	7
6	DSR	←	DSR	6
7	RTS	→	RTS	4
8	CTS	←	CTS	5
9	RI	←	RI	22
Shell	GND	↔	GND	Shell

\* Arrows indicate which direction the signal is flowing

#### NOTES:

- Altpin should be turned off when using this cable.
- This cable utilizes the CTS signal of the modem for hardware flow control (RTS/CTS).

# DB-25F to DB-9M Modem Cable

## Modem Cables

### EIA-232 Modem Cables DB-25 to DB-9

The wiring diagram for a DB-25 to DB-9 modem cable is shown in Table 1.

**Table 1: EIA-232 DB-25 to DB-9 modem cable**

From DB-25	Signal	Direction	Signal	To DB-9
8	DCD	←	DCD	1
3	RxD	←	RxD	2
2	TxD	→	TxD	3
20	DTR	→	DTR	4
7	SG	↔	SG	5
6	DSR	←	DSR	6
4	RTS	→	RTS	7
5	CTS	←	CTS	8
22	RI	←	RI	9
Shell	GND	↔	GND	Shell

\* Arrows indicate which direction the signal is flowing

#### NOTES:

- Altpin should be turned off when using this cable.
- This cable utilizes the CTS signal of the modem for hardware flow control (RTS/CTS).

# DB-25F to DB-25M Modem Cable

## Modem Cables

### EIA-232 Modem Cables DB-25 to DB-25

The wiring diagram for a DB-25 to DB-25 modem cable is shown in Table 1.

**Table 1: EIA-232 DB-25 to DB-25 modem cable**

From DB-25	Signal	Direction	Signal	To DB-25
8	DCD	←	DCD	8
3	RxD	←	RxD	3
2	TxD	→	TxD	2
20	DTR	→	DTR	20
7	SG	↔	SG	7
6	DSR	←	DSR	6
4	RTS	→	RTS	4
5	CTS	←	CTS	5
22	RI	←	RI	22
Shell	GND	↔	GND	Shell

\* Arrows indicate which direction the signal is flowing

#### NOTES:

- Altpin should be turned off when using this cable.
- This cable utilizes the CTS signal of the modem for hardware flow control (RTS/CTS).
- EIA-232 cables cannot exceed 2500pF.

# SCSI Terminal Server DB-25M to DB-9M Modem Cable

## Modem Cables

### Modem Cables DB-25 to DB-9

**EIA-232 Boards which require DB-25 Male Cables Connectors-** SCSI Terminal Server ST1002, SCSI Terminal Server ST1008, SCSI Terminal Server ST1016, SCSI Terminal Server ST1600

The wiring diagram for a DB-25 to DB-9 modem cable is shown in Table 1.

**Table 1: EIA-232 DB-25 to DB-9 modem cable**

From DB-25	Signal	Direction	Signal	To DB-9
8	DCD	←	DCD	1
3	RxD	←	RxD	2
2	TxD	→	TxD	3
20	DTR	→	DTR	4
7	SG	↔	SG	5
6	DSR	←	DSR	6
4	RTS	→	RTS	7
5	CTS	←	CTS	8
22	RI	←	RI	9
Shell	GND	↔	GND	Shell

\* Arrows indicate which direction the signal is flowing

#### NOTES:

- This cable utilizes the CTS signal of the modem for hardware flow control (RTS/CTS).

# RJ-45 (Altpin On) to DB-9M Modem Cable

## Modem Cables

### EIA-232 Modem Cables Altpin RJ-45 8-pin to DB-9

The wiring diagram for an altpin RJ-45 8-pin to DB-9 modem cable is shown in Table 1.

**Table 1: EIA-232 altpin RJ-45 8-pin to DB-9 modem cable**

From RJ-45	Signal	Direction	Signal	To DB-9
1	DCD	←	DCD	1
5	RxD	←	RxD	2
4	TxD	→	TxD	3
8	DTR	→	DTR	4
6	SG	↔	SG	5
2	RTS	→	RTS	7
7	CTS	←	CTS	8
3	GND	↔	GND	Shell

FRONT:



RJ-45 8-Pin

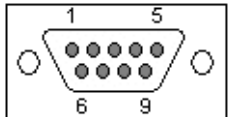

Male DB-9

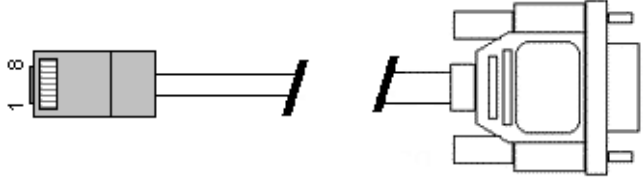

Connectors not to scale

\* Arrows indicate which direction the signal is flowing

#### NOTES:

- Altpin should be turned on when using this cable.
- This cable utilizes the CTS signal of the modem for hardware flow control (RTS/CTS).



# RJ-45 (Altpin On) to DB-25M Modem Cable

## Modem Cables

### EIA-232 Modem Cables, Altpin RJ-45 8-pin to DB-25

The wiring diagram for a Altpin RJ-45 8-pin to DB-25 modem cable is shown in Table 1.

**Table 1: EIA-232 Altpin RJ-45 8-pin to DB-25 modem cable**

From RJ-45	Signal	Direction	Signal	To DB-25
1	DCD	←	DCD	8
5	RxD	←	RxD	3
4	TxD	→	TxD	2
8	DTR	→	DTR	20
6	SG	↔	SG	7
2	RTS	→	RTS	4
7	CTS	←	CTS	5
3	GND	↔	GND	Shell

\* Arrows indicate which direction the signal is flowing

#### NOTES:

- Altpin should be turned on when using this cable.
- This cable utilizes the CTS signal of the modem for hardware flow control (RTS/CTS).

# RJ-45 10 Pin to DB-9M Modem Cable

## Modem Cables

### EIA-232 Modem Cables RJ-45 10-pin to DB-9

The wiring diagram for an RJ-45 10-pin to DB-9 modem cable is shown in Table 1.

**Table 1: EIA-232 RJ-45 10-pin to DB-9 modem cable**

From RJ-45	Signal	Direction	Signal	To DB-9
10	DCD	←	DCD	1
6	RxD	←	RxD	2
5	TxD	→	TxD	3
9	DTR	→	DTR	4
7	SG	↔	SG	5
2	DSR	←	DSR	6
3	RTS	→	RTS	7
8	CTS	←	CTS	8
1	RI	←	RI	9
4	GND	↔	GND	Shell

FRONT:



RJ-45 10-Pin

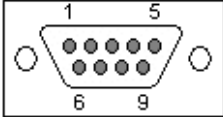

Male DB-9

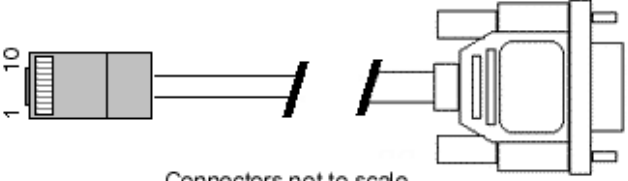

Connectors not to scale

\* Arrows indicate which direction the signal is flowing

These cables can also be purchased from Digi (See part numbers below).

- 2' RJ-45 10-pin to DB-9 Pin - Part #76000239
- 4' RJ-45 10-pin to DB-9 Pin - Part #76000240

#### NOTES:

- Altpin should be turned off when using this cable.
- This cable utilizes the CTS signal of the modem for hardware flow control (RTS/CTS).

# RJ-45 10 Pin to DB-25M Modem Cable

## Modem Cables

### EIA-232 Modem Cables RJ-45 10-pin to DB-25

The wiring diagram for a RJ-45 10-pin to DB-25 pin modem cable is shown in Table 1.

**Table 1: EIA-232 RJ-45 10-pin to DB-25**

From RJ-45	Signal	Direction	Signal	To DB-25
10	DCD	←	DCD	8
6	RxD	←	RxD	3
5	TxD	→	TxD	2
9	DTR	→	DTR	20
7	SG	↔	SG	7
2	DSR	←	DSR	6
3	RTS	→	RTS	4
8	CTS	←	CTS	5
1	RI	←	RI	22
Shell	GND	↔	GND	Shell

\* Arrows indicate which direction the signal is flowing

These cables can also be purchased from Digi (See part numbers below).

- 2' RJ-45 10-pin to DB-25 Pin - Part #76000129
- 4' RJ-45 10-pin to DB-25 Pin - Part #76000195

#### NOTES:

- Altpin should be turned off when using this cable.
- This cable utilizes the CTS signal of the modem for hardware flow control (RTS/CTS).

# DB-9F to DB-9F Terminal Emulator Cable

## Cables

### EIA-232 PC Terminal Emulator Cables, DB-9 to DB-9

The wiring diagram for a DB-9 to DB-9 PC terminal emulator cable is shown in Table 1.

**Table 1: EIA-232 DB-9 to DB-9 PC terminal emulator cable**

DB-9	Signal	Direction	Signal	To DB-9
2	RxD	←	TxD	3
3	TxD	→	RxD	2
4	DTR	↻	DSR	6
			DCD	1
5	SG	↔	SG	5
6	DSR	↻	DTR	4
1	DCD			
7	RTS	→	CTS	8
8	CTS	←	RTS	7
Shell	GND	↔	GND	Shell

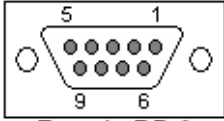
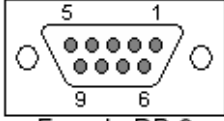
Connectors not to scale

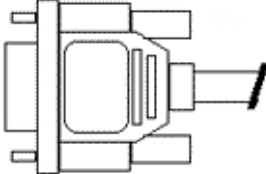
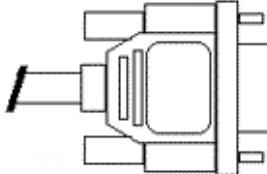
\* Arrows indicate which direction the signal is flowing

#### NOTES:

- Altpin should be turned off when using this cable.
- This cable utilizes the RTS signal of the PC terminal emulator for hardware flow control (RTS/CTS).

# DB-9F to DB-25F Terminal Emulator Cable

## Cables

### EIA-232 PC Terminal Emulator Cables, DB-9 to DB-25

The wiring diagram for a DB-9 to DB-25 PC terminal emulator cable is shown in Table 1.

**Table 1: EIA-232 DB-9 to DB-25 PC terminal emulator cable**

DB-9	Signal	Direction	Signal	To DB-25
2	RxD	←	TxD	2
3	TxD	→	RxD	3
4	DTR	↻	DSR	6
			DCD	8
5	SG	↔	SG	7
6	DSR	↻	DTR	20
1	DCD	↻		
7	RTS	→	CTS	5
8	CTS	←	RTS	4
Shell	GND	↔	GND	Shell

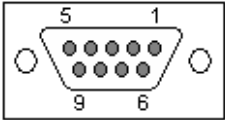
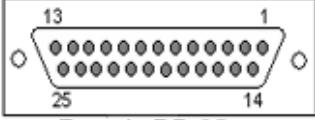

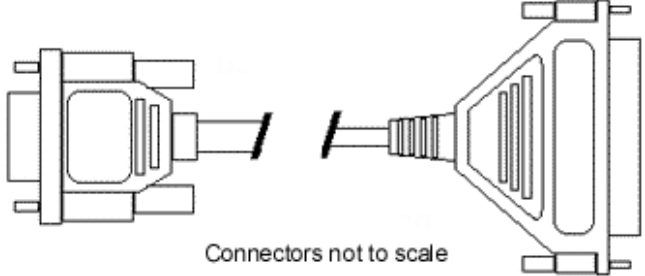
Connectors not to scale

\* Arrows indicate which direction the signal is flowing

#### NOTES:

- Altpin should be turned off when using this cable.
- This cable utilizes the RTS signal of the PC terminal emulator for hardware flow control (RTS/CTS).

# DB-25F to DB-9F Terminal Emulator Cable

## Cables

### EIA-232 PC Terminal Emulator Cables, DB-25 to DB-9

The wiring diagram for a DB-25 to DB-9 PC terminal emulator cable is shown in Table 1.

**Table 1: EIA-232 DB-25 to DB-9 PC terminal emulator cable**

From Port DB-25	Signal	Direction	Signal	To Term/Prn DB-9
6	DSR	↔	DTR	4
8	DCD			
3	RxD	←	TxD	3
2	TxD	→	RxD	2
20	DTR	↔	DSR	6
			DCD	1
7	SG	↔	SG	5
4	RTS	→	CTS	8
5	CTS	←	RTS	7
Shell	GND	↔	GND	Shell

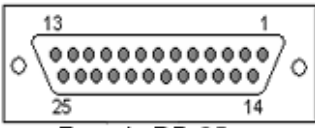
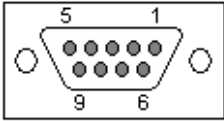

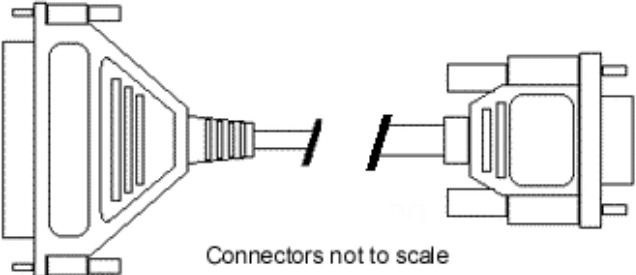
\* Arrows indicate which direction the signal is flowing

#### NOTES:

- Altpin should be turned off when using this cable.
- This cable utilizes the RTS signal of the PC terminal emulator for hardware flow control (RTS/CTS).

# DB-25F to DB-25F Terminal Emulator Cable

## Cables

### EIA-232 PC Terminal Emulator Cables, DB-25 to DB-25

>

The wiring diagram for a DB-25 to DB-25 PC Terminal Emulator cable is shown in Table 1.

**Table 1: EIA-232 DB-25 to DB-25 PC terminal emulator cable**

From Port DB-25	Signal	Direction	Signal	To Term/Prn DB-25
6	DSR	↔	DTR	20
8	DCD			
3	RxD	←	TxD	2
2	TxD	→	RxD	3
20	DTR	↔	DSR	6
			DCD	8
7	SG	↔	SG	7
4	RTS	→	CTS	5
5	CTS	←	RTS	4
Shell	GND	↔	GND	Shell

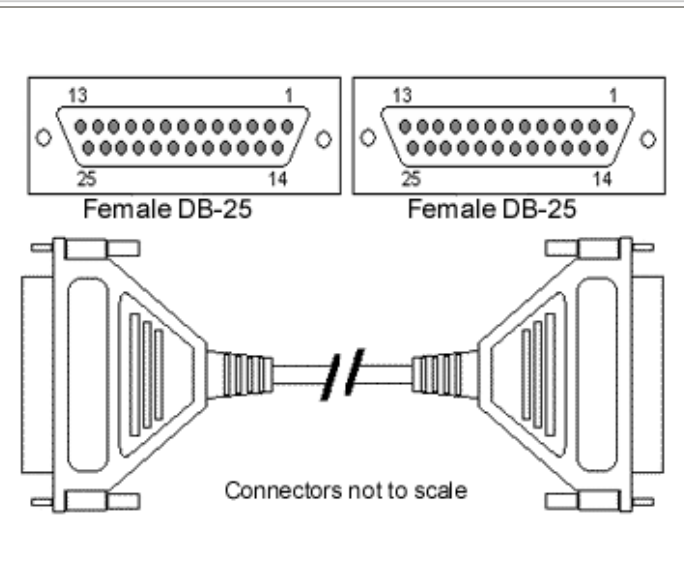

\* Arrows indicate which direction the signal is flowing

#### NOTES:

- Altpin should be turned off when using this cable.
- This cable utilizes the RTS signal of the PC terminal emulator for hardware flow control (RTS/CTS).

# SCSI Terminal Server DB-25M to DB-9F Terminal Emulator Cable

## Cables

### PC Terminal Emulator Cables, DB-25 to DB-9

EIA-232 Boards which require DB-25 Male Cables Connectors - SCSI Terminal Server ST1002, SCSI Terminal Server ST1008, SCSI Terminal Server ST1016, SCSI Terminal Server ST1600

The wiring diagram for a DB-25 to DB-9 PC terminal emulator cable is shown in Table 1.

**Table 1: EIA-232 DB-25 to DB-9 PC terminal emulator cable**

From Port DB-25	Signal	Direction	Signal	To Term/Prn DB-9
6	DSR	↔	DTR	4
8	DCD			
3	RxD	←	TxD	3
2	TxD	→	RxD	2
20	DTR	↔	DSR	6
			DCD	1
7	SG	↔	SG	5
4	RTS	→	CTS	8
5	CTS	←	RTS	7
Shell	GND	↔	GND	Shell

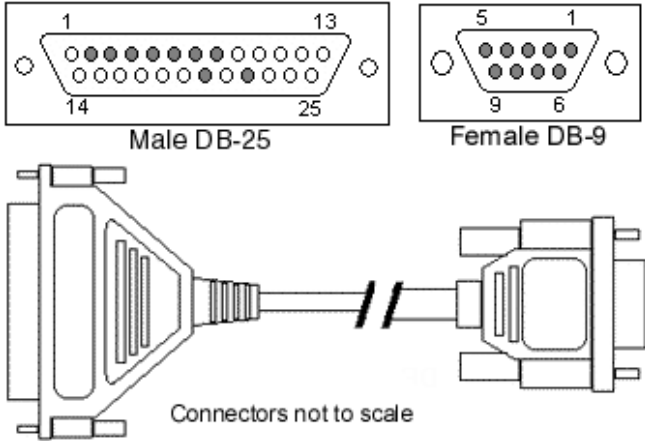

\* Arrows indicate which direction the signal is flowing



# SCSI Terminal Server DB-25M to DB-25F Terminal Emulator Cable

## Cables

### PC Terminal Emulator Cables, DB-25 to DB-25

EIA-232 Boards which require DB-25 Male Cables Connectors- SCSI Terminal Server ST1002, SCSI Terminal Server ST1008, SCSI Terminal Server ST1016, SCSI Terminal Server ST1600

The wiring diagram for a DB-25 to DB-25 PC Terminal Emulator cable is shown in Table 1.

**Table 1: EIA-232 DB-25 to DB-25 PC terminal emulator cable**

From Port DB-25	Signal	Direction	Signal	To Term/Prn DB-25
6	DSR	↕	DTR	20
8	DCD			
3	RxD	←	TxD	2
2	TxD	→	RxD	3
20	DTR	↕	DSR	6
			DCD	8
7	SG	↔	SG	7
4	RTS	→	CTS	5
5	CTS	←	RTS	4
Shell	GND	↔	GND	Shell

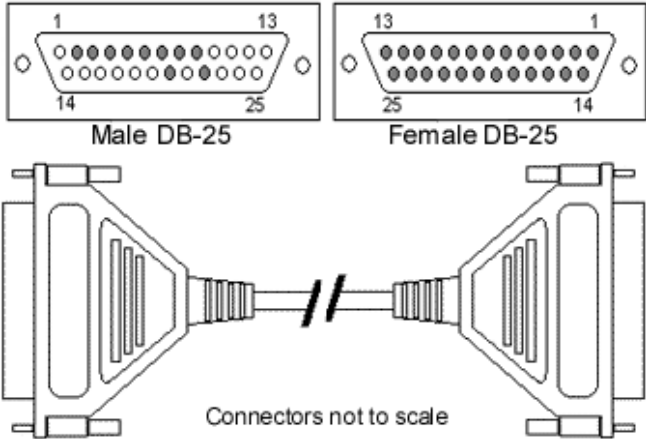

\* Arrows indicate which direction the signal is flowing

# RJ-11 6 Pin/4-Wire to DB-9F Terminal Emulator Cable

## Cables

### EIA-232 PC Terminal Emulator Cables, RJ-11 6-pin/4-wire to DB-9

The wiring diagram for an RJ-11 6-pin/4-wire to DB-9 PC terminal emulator cable is shown in Table 1.

**Table 1: EIA-232 RJ-11 6-pin/4-wire to DB-9 PC terminal emulator cable**

From RJ-11	Signal	Direction	Signal	To DB-9
4	RxD	←	TxD	3
3	TxD	→	RxD	2
5	SG	↔	SG	5
2	GND	↔	GND	Shell



FRONT:  
RJ-11 6-pin

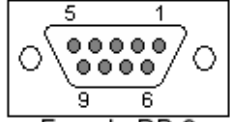

Female DB-9

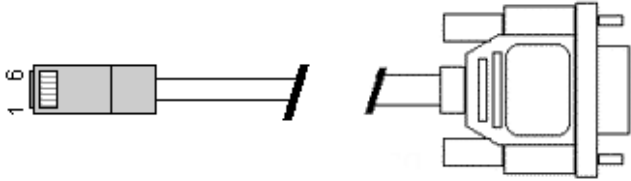

Connectors not to scale

\* Arrows indicate which direction the signal is flowing

#### NOTES:

- This cable can only be used with Software Flow Control (Xon/Xoff).
- Some Unix operating systems require carrier to be present. If this is the case, the `forcedcd` parameter will need to be turned on for this port at the host.

# RJ-11 6 Pin/4-Wire to DB-25F Terminal Emulator Cable Software Flow Control Only

## Cables

### EIA-232 PC Terminal Emulator Cables, RJ-11 6-pin/4-wire to DB-25

#### Software Flow Control Only

The wiring diagram for an RJ-11 6-pin/4-wire to DB-25 PC terminal emulator cable is shown in Table 1.

**Table 1: EIA-232 RJ-11 6-pin/4-wire to DB-25 PC terminal emulator cable**

From RJ-11	Signal	Direction	Signal	To DB-25
4	RxD	←	TxD	2
3	TxD	→	RxD	3
5	SG	↔	SG	7
2	GND	↔	GND	Shell

\* Arrows indicate which direction the signal is flowing

#### NOTES:

- This cable can only be used with Software Flow Control (Xon/Xoff).
- Some Unix operating systems require carrier to be present. If this is the case, the `forcedcd` parameter will need to be turned on for this port at the host.

# RJ-11 6 Pin to DB-9F Terminal Emulator Cable

## Cables

### EIA-232 PC Terminal Emulator Cables, RJ-11 6-pin to DB-9

The wiring diagram for an RJ-11 6-pin to DB-9 PC terminal emulator cable is shown in Table 1.

**Table 1: EIA-232 RJ-11 6-pin to DB-9 PC terminal emulator cable**

From RJ-11	Signal	Direction	Signal	To DB-9
4	RxD	←	TxD	3
3	TxD	→	RxD	2
5	SG	↔	SG	5
1	RTS	→	CTS	8
6	CTS	←	RTS	7
2	GND	↔	GND	Shell

The diagram shows the physical connectors and their pin configurations. On the left is an RJ-11 6-pin connector with pins labeled 6 and 1. On the right is a Female DB-9 connector with pins labeled 5, 1, 9, and 6. Below these are perspective drawings of the connectors. The text 'Connectors not to scale' is centered below the drawings.

\* Arrows indicate which direction the signal is flowing

#### NOTES:

- This cable utilizes the RTS signal of the PC terminal emulator for hardware flow control (RTS/CTS).
- Some Unix operating systems require carrier to be present. If this is the case, the `forcedcd` parameter will need to be turned on for this port at the host.

# RJ-11 6 Pin to DB-25F Terminal Emulator Cable

## Cables

### EIA-232 PC Terminal Emulator Cables, RJ-11 6-pin to DB-25

The wiring diagram for an RJ-11 6-pin to DB-25 PC terminal emulator cable is shown in Table 1.

**Table 1: EIA-232 RJ-11 6-pin to DB-25 PC terminal emulator cable**

From RJ-11	Signal	Direction	Signal	To DB-25
1	RTS	→	CTS	5
4	RxD	←	TxD	2
3	TxD	→	RxD	3
5	SG	↔	SG	7
2	GND	↔	GND	Shell
6	CTS	←	RTS	4

\* Arrows indicate which direction the signal is flowing

#### NOTES:

- This cable utilizes the RTS signal of the PC terminal emulator for hardware flow control (RTS/CTS).
- Some Unix operating systems require carrier to be present. If this is the case, the `forcedcd` parameter will need to be turned on for this port at the host.

# RJ-45 4-Wire to DB-9F Terminal Emulator Cable Software Flow Control Only

## Cables

### EIA-232 PC Terminal Emulator Cables, RJ-45 8-pin/4-wire to DB-9

#### Software Flow Control Only

The wiring diagram for an RJ-45 8-pin to DB-9 PC terminal emulator cable using only 4 wires is shown in Table 1.

**Table 1: EIA-232 RJ-45 8-pin to DB-9 PC terminal emulator cable using only 4 wires**

From RJ-45	Signal	Direction	Signal	To DB-9
3	GND	↔	GND	Shell
4	TxD	→	RxD	2
5	RxD	←	TxD	3
6	SG	↔	SG	5
1	DCD	←	RTS	7

Connectors not to scale

\* Arrows indicate which direction the signal is flowing

#### NOTES:

- This cable can only be used with Software Flow Control (Xon/Xoff).
- Some Unix operating systems require carrier to be present. If this is the case, altpin must be turned on and the DCD-RTS wire added (in some cases it may be possible to wire DCD-RTS as the fourth wire instead of GND).

# RJ-45 4-Wire to DB-25F Terminal Emulator Cable Software Flow Control Only

## Cables

### EIA-232 PC Terminal Emulator Cables, RJ-45 8-pin/4-wire to DB-25

#### Software Flow Control Only

The wiring diagram for an RJ-45 8-pin to DB-25 PC terminal emulator cable using only 4 wires is shown in Table 1.

**Table 1: EIA-232 RJ-45 8-pin to DB-25 PC terminal emulator cable using only 4 wires**

From RJ-45	Signal	Direction	Signal	To DB-25
3	GND	↔	GND	Shell
4	TxD	→	RxD	3
5	RxD	←	TxD	2
6	SG	↔	SG	7
1	DCD	←	RTS	4

\* Arrows indicate which direction the signal is flowing

#### NOTES:

- This cable can only be used with Software Flow Control (Xon/Xoff).
- Some Unix operating systems require carrier to be present. If this is the case, altpin must be turned on and the DCD-RTS wire added (in some cases it may be possible to wire DCD-RTS as the fourth wire instead of GND).

## RJ-45 (Altpin On) to DB-9F Terminal Emulator Cable

### Cables

## PC Terminal Emulator Cables, Altpin RJ-45 8-pin to DB-9

The wiring diagram for an altpin RJ-45 8-pin to DB-9 PC terminal emulator cable is shown in Table 1.

**Table 1: EIA-232 altpin RJ-45 8-pin to DB-9 PC terminal emulator cable**

From RJ-45	Signal	Direction	Signal	To DB-9
3	GND	↔	GND	Shell
4	TxD	→	RxD	2
5	RxD	←	TxD	3
6	SG	↔	SG	5
7	CTS	←	RTS	7
1	DCD	←	DTR	4
2	RTS	→	CTS	8
8	DTR	→	DSR	6

FRONT:



RJ-45 8-Pin

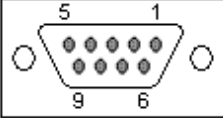

Female

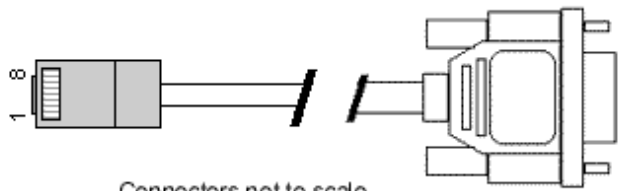

Connectors not to scale

\* Arrows indicate which direction the signal is flowing

### NOTES:

- Altpin should be turned on when using this cable so that DTR will drive DCD (standard usage).
- If altpin is turned off, the hardware signal on RJ45 pin 1 becomes DSR instead of DCD. This alternative can be used if DCD is not required, and DSR is needed instead.
- This cable utilizes the RTS signal of the PC terminal emulator for hardware flow control (RTS/CTS).



## RJ-45 (Altpin On) to DB-25F Terminal Emulator Cable

### Cables

## EIA-232 PC Terminal Emulator Cables, Altpin RJ-45 8-pin to DB-25

The wiring diagram for an altpin RJ-45 8-pin to DB-25 PC terminal emulator cable is shown in Table 1.

**Table 1: EIA-232 altpin RJ-45 8-pin to DB-25 PC terminal emulator cable**

From RJ-45	Signal	Direction	Signal	To DB-25
7	CTS	←	RTS	4
5	RxD	←	TxD	2
4	TxD	→	RxD	3
8	DTR	↔	DSR	6
			DCD	8
6	SG	↔	SG	7
2	RTS	→	CTS	5
1	DCD	←	DTR	20
3	GND	↔	GND	Shell

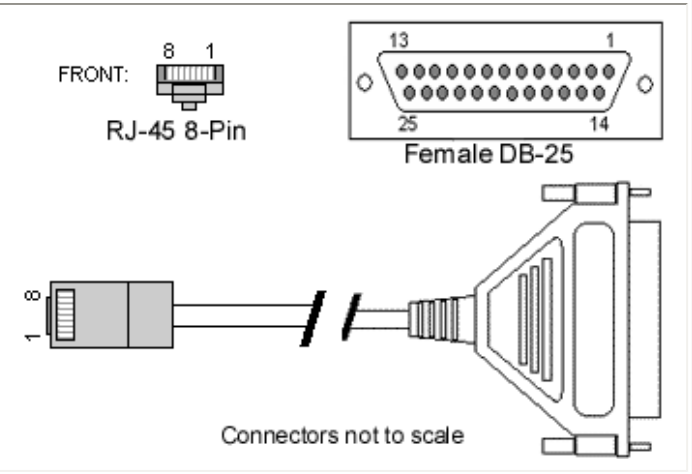

\* Arrows indicate which direction the signal is flowing

### NOTES:

- Altpin should be turned on when using this cable so that DTR will drive DCD (standard usage).
- If altpin is turned off, the hardware signal on RJ45 pin 1 becomes DSR instead of DCD. This alternative can be used if DCD is not required, and DSR is needed instead.

## RJ-45 to DB-9F Terminal Emulator Cable

### PC Terminal Emulator Cables, RJ-45 8-pin to DB-9

The wiring diagram for an RJ-45 8-pin to DB-9 PC terminal emulator cable is shown in Table 1.

**Table 1: EIA-232 RJ-45 8-pin to DB-9 PC terminal emulator cable**

From RJ-45	Signal	Direction	Signal	To DB-9
3	GND	↔	GND	Shell
4	TxD	→	RxD	2
5	RxD	←	TxD	3
6	SG	↔	SG	5
7	CTS	←	RTS	7
1	DSR	←	DTR	4
2	RTS	→	CTS	8
8	DTR	→	DSR	6

\* Arrows indicate which direction the signal is flowing

#### NOTES:

- Altpin should be turned off when using this cable so that pin 1 becomes DSR instead of DCD. This alternative can be used if DCD is not required, and DSR is needed instead.
- This cable utilizes the RTS signal of the PC terminal emulator for hardware flow control (RTS/CTS).

# RJ-45 10 Pin to DB-9F Terminal Emulator Cable

## Cables

### EIA-232 PC Terminal Emulator Cables, RJ-45 10-pin to DB-9

The wiring diagram for an RJ-45 10-pin to DB-9 PC terminal emulator cable is shown in Table 1.

**Table 1: EIA-232 RJ-45 10-pin to DB-9 PC terminal emulator cable**

From RJ-45	Signal	Direction	Signal	To DB-9
10	DCD	↔	DTR	4
2	DSR			
6	RxD	←	TxD	3
5	TxD	→	RxD	2
9	DTR	↔	DSR	6
			DCD	1
7	SG	↔	SG	5
3	RTS	→	CTS	8
8	CTS	←	RTS	7
4	GND	↔	GND	Shell

\* Arrows indicate which direction the signal is flowing

#### NOTES:

- Altpin should be turned off when using this cable.
- This cable utilizes the RTS signal of the PC terminal emulator for hardware flow control (RTS/CTS).

# RJ-45 10 Pin to DB-25F Terminal Emulator Cable

## Cables

### EIA-232 PC Terminal Emulator Cables, RJ-45 10-pin to DB-25

The wiring diagram for an RJ-45 10-pin to DB-25 PC terminal emulator cable is shown in Table 1.

**Table 1: EIA-232 RJ-45 10-pin to DB-25 PC terminal emulator cable**

From RJ-45	Signal	Direction	Signal	To DB-25
10	DCD	↕	DTR	20
2	DSR			
6	RxD	←	TxD	2
5	TxD	→	RxD	3
9	DTR	↕	DSR	6
			DCD	8
7	SG	↔	SG	7
3	RTS	→	CTS	5
8	CTS	←	RTS	4
4	GND	↔	GND	Shell

\* Arrows indicate which direction the signal is flowing

#### NOTES:

- Altpin should be turned off when using this cable.
- This cable utilizes the RTS signal of the PC terminal emulator for hardware flow control (RTS/CTS).

# RJ-45 (Altpin On) to RJ-45 Cisco Console Adapter

## Adapter Cables

### Digi - Cisco Console Adapter, Altpin RJ-45 to RJ-45

The wiring diagram for an Altpin RJ-45 8-pin to a Cisco Console RJ-45 8-pin adapter cable is shown in Table 1.

The Following cables are available from Digi:

- 76000631 Qty-1 6' Cisco/SUN Netra
- 76000632 Qty-8 6' Cisco/SUN Netra
- 76000633 Qty-16 6' Cisco/SUN Netra

**Table 1: EIA-232 Altpin RJ-45 to RJ-45**

From RJ-45	Signal	Direction	Signal	To RJ-45 Cisco
1	DCD	←	DTR	2
5	RxD	←	TxD	3
4	TxD	→	RxD	6
8	DTR	→	DSR	7
6	SG	↔	SG	5
2	RTS	→	CTS	8
7	CTS	←	RTS	1
3	GND	↔	GND	4



FRONT: RJ-45 8-Pin



FRONT: RJ-45 8-Pin

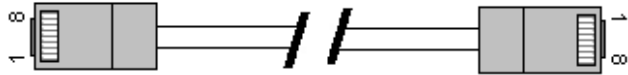

Connectors not to scale

- Arrows indicate which direction the signal is flowing

#### NOTES:

- Works for most current Cisco routers.
- Be careful not to swap cable ends. One end will go to DIGI and the other to the router.
- Altpin should be turned on when using this cable.

## V.35 to DB-25M Cabling

V.35 (DB25)	
Pin #	Signal
1	CGND
2	TxD
3	RxD
4	RTS
5	CTS
6	DSR
7	GND
8	DCD
9	RxCLK(A)
11	TxCLOUT(A)
12	TxCLKIN(A)
14	TxD(B)
15	TxCIN
16	RxD(B)
17	RxC
20	DTR
24	TxOUT
Shell	CGND

This V.35 cabling option provides a DB25 Male connector.

This cable type is capable of handling data rates up to 2.048Mbps (E1) as well as lower speeds (9600, 19200, 56000, etc.).

## V.35 Pinout

### V.35 Pinout

**V.35 Boards with Winchester cable assemblies (see part numbers for cables below) - Sync 570 (EIA-232 only), Sync 570i (X.21/EIA-530), Sync 570i (EIA-232/V.35), Sync 570i UIB (PCI boards), Syncport, Sync 2000.**

- Sync 2000 single port V.35 cable - Part #77000427
- Sync 570i UIB single port V.35 cable - Part #76000292
- Sync 570i 2 port V.35 cable - Part #62500046
- Sync 570i 4 port V.35 cable - Part #62500051
- DB-25 to Winchester convertor for ISA Sync 570i - Part #62500041

V.35	Direction	Signal
A	↔	CGND
B	↔	GND
C	→	RTS
D	←	CTS
E	←	DSR
F	←	DCD
H	←	DTR
P	→	TxD+
R	←	RxD+
S	→	TxD-
T	←	RxD-
U	→	TXcLK External +
V	←	RxCk+
W	→	TxCk External -
X	←	RxCk-
Y	←	TxCk In +
AA	←	TxCk In -
Shell	↔	GND

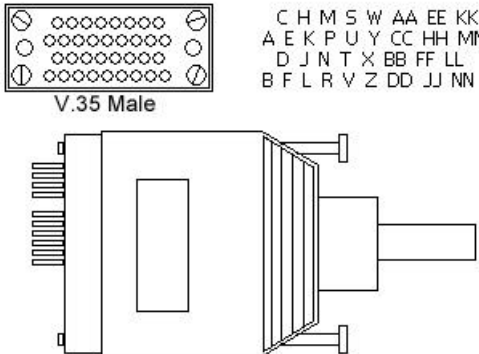

V.35 Male

C H M S W AA EE KK  
A E K P U Y CC HH MM  
D J N T X BB FF LL  
B F L R V Z DD JJ NN

## X.21 V.11 to DB-15 Cable

### X.21/V.11 Pinout

DB-25	Direction	Signal
1	↔	CGND
2	→	TxD+
3	←	RxD+
4	→	RTS+
5	←	CTS+
6	←	DCE Ready +
7	↔	SG
8	←	Received Line Signal Indicator +
9	←	RxClk +
10	←	Recieved Lne Signal Indicator -
11	→	TxClk External +
12	←	TxClk Internal -
13	←	CTS-
14	→	TxD-
15	←	TxClk Internal +
16	←	RxD-
17	←	RxClk-
19	→	RTS-
20	→	DTE Ready +
22	←	DCE Ready +
23	→	DTE Ready -
24	→	TxClk External -
Shell	↔	GND

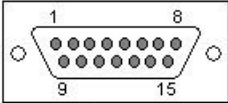

Male

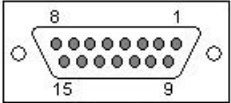

Female

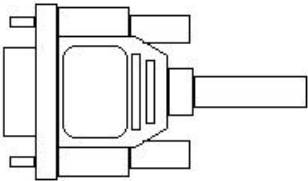

#### NOTES:

**X.21/V.11 Boards with DB-15 cable assemblies (see part numbers for cables below)** - Sync 570 (EIA-232 only), Sync 570i (EIA-232/V.35), Sync 570i UIB (PCI boards), Syncport, Sync 2000.

- Sync 2000 single port X.21/V.11 DB-15 cable - Part #77000426
- Sync 570i UIB single port X.21/V.11 DB-15 cable - Part #76000294
- Sync 570i 2 port X.21/V.11 DB-15 cable - Part #62500038
- Sync 570i 4 port cable (three port X.21/V.11 DB-15) - Part #62500048
- Sync 570i 4 port cable X.21/V.11 DB-15 cable - Part #62500047



## Digi AccelePort Xp and NEO HD-68 Pin Ultra SCSI Connector

The connector provides a connection for the RS232 signals on the PCB to a cable to interface various 4, 8 and 16 port peripheral devices. The first table is for ports 1-8 and the second table is for ports 9-16. The pin-outs for the connector and the asynchronous ports configuration is as follows:

see Table 1 for: Ports 1-8 of HD-68 Connector for 4 or 8 port boards.

see Table 2 for: Ports 9-16 of second HD-68 Connector when using 16 port board.

**Table 1: PORTS 1-8 of HD-68 Connector for 4, 8 or 16 port boards**

**Table 1:**

68 Pin Ultra SCSI	Wire name	Male DB-25 Connector	68 Pin Ultra SCSI	Wire name	Male DB-25 Connector
1	Rx-D7	P7-3	35	Rx-D8	P8-3
2	CTS7	P7-5	36	CTS8	P8-5
3	R17	P7-22	37	R18	P8-22
4	RTS7	P7-4	38	RTS8	P8-4
5	DCD7	P7-8	39	DCD8	P8-8
6	DTR7	P7-20	40	DTR8	P8-20
7	DSR7	P7-6	41	DSR8	P8-6
8	TxD7	P7-2	42	TxD8	P8-2
9	GND	P7-7, P5-7	43	GND	P8-7, P6-7
10	TxD5	P5-2	44	TxD6	P5-2
11	DSR5	P5-6	45	DSR6	P6-6
12	DTR5	P5-20	46	DTR6	P6-20
13	DCD5	P5-8	47	DCD6	P6-8
14	RTS5	P5-4	48	RTS6	P6-4
15	R15	P5-22	49	R16	P6-22
16	CTS5	P5-5	50	CTS6	P6-5
17	RXD5	P5-3	51	RXD6	P6-3
18	RxD3	P3-3	52	RxD4	P4-3
19	CTS3	P3-5	53	CTS4	P4-5
20	R13	P3-22	54	R14	P4-22
21	RTS3	P3-4	55	RTS4	P4-4
22	DCD3	P3-8	56	DCD4	P4-8
23	DTR3	P3-20	57	DTR4	P4-20
24	DSR3	P3-6	58	DSR4	P4-6
25	TxD3	P3-2	59	TxD4	P4-2

**Table 1:**

68 Pin Ultra SCSI	Wire name	Male DB-25 Connector	68 Pin Ultra SCSI	Wire name	Male DB-25 Connector
26	GND	P3-7, P1-7	60	GND	P4-7, P2-7
27	TxD1	P1-2	61	TxD2	P2-2
28	DSR1	P1-6	62	DSR2	P2-6
29	DTR1	P1-20	63	DTR2	P2-20
30	DCD1	P1-8	64	DCD2	P2-8
31	RTS1	P1-4	65	RTS2	P2-4
32	R11	P1-22	66	R12	P2-22
33	CTS1	P1-5	67	CTS2	P2-5
34	RXD1	P1-3	68	RXD2	P2-3

**Table 2: PORTS 9-16 of second HD-68 Connector when using 16 port board**

68 Pin Ultra SCSI	Wire name	Male DB-25 Connector	68 Pin Ultra SCSI	Wire name	Male DB-25 Connector
1	RxD15	P15-3	35	RxD16	P16-3
2	CTS15	P15-5	36	CTS16	P16-5
3	RI15	P15-22	37	RI16	P16-22
4	RTS15	P15-4	38	RTS16	P16-4
5	DCD15	P15-8	39	DCD16	P16-8
6	DTR15	P15-20	40	DTR16	P16-20
7	DSR15	P15-6	41	DSR16	P16-6
8	TxD15	P15-2	42	TxD16	P16-2
9	GND	P15-7, P13-7	43	GND	P16-7, P14-7
10	TxD13	P13-2	44	TxD14	P14-2
11	DSR13	P13-6	45	DSR14	P14-6
12	DTR13	P13-20	46	DTR14	P14-20
13	DCD13	P13-8	47	DCD14	P14-8
14	RTS13	P13-4	48	RTS14	P14-4
15	RI13	P13-22	49	RI14	P14-22
16	CTS13	P13-5	50	CTS14	P14-5
17	RXD13	P13-3	51	RXD14	P14-3
18	RxD11	P11-3	52	RxD12	P12-3
19	CTS11	P11-5	53	CTS12	P12-5

20	RI11	P11-22	54	RI12	P12-22
21	RTS11	P11-4	55	RTS12	P12-4
22	DCD11	P11-8	56	DCD12	P12-8
23	DTR11	P11-20	57	DTR12	P12-20
24	DSR11	P11-6	58	DSR12	P12-6
25	TxD11	P11-2	59	TxD12	P12-2
26	GND	P11-7, P9-7	60	GND	P12-7, P10-7
27	TxD9	P9-2	61	TxD10	P10-2
28	DSR9	P9-6	62	DSR10	P10-6
29	DTR9	P9-20	63	DTR10	P10-20
30	DCD9	P9-8	64	DCD10	P10-8
31	RTS9	P9-4	65	RTS10	P10-4
32	RI9	P9-22	66	RI10	P10-22
33	CTS9	P9-5	67	CTS10	P10-5
34	RXD9	P9-3	68	RXD10	P10-3

## Sync V.24 DB-25 Connector Pinout

### V.24 (EIA-232) Pinout

**V.24 (EIA-232) Boards with DB-25 cable assemblies (see part numbers for cables below) -**  
 Sync 570 (EIA-232 only), Sync 570i (EIA-232/V.35), Sync 570i UIB (PCI boards), Syncport,  
 Sync 2000.

- Sync 2000 single port EIA-232 (V.24) DB-25 cable - Part #77000428
- Sync 570i UIB single port EIA-232 DB-25 cable - Part #76000293
- Sync 570/570i 2 port EIA-232 DB-25 - - Part #62500037
- Sync 570/570i 4 port EIA-232 DB-25 - Part #62500036

DB-25	Direction	Signal
1	↔	CGND
2	➔	TxD+
3	➔	RxD+
4	➔	RTS
5	➔	CTS
6	➔	DSR
7	↔	GND
8	➔	DCD
15	➔	TxCk Internal
17	➔	RxCk
20	➔	DTR
24	➔	TxCk External
Shell	↔	GND

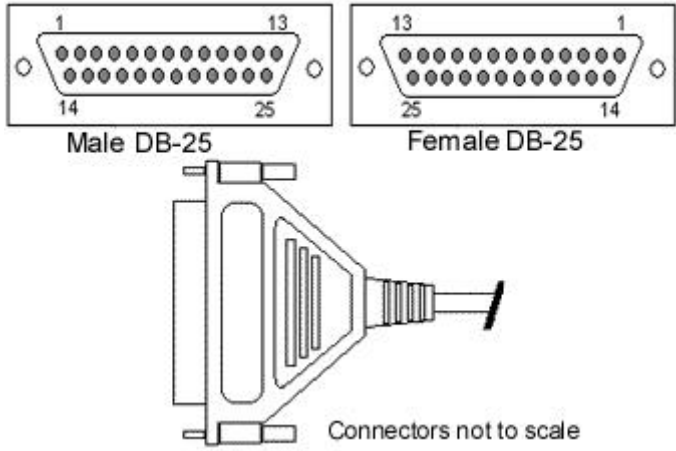

Connectors not to scale

## EIA 422 DB-25 Pinouts for Sync Boards

Sync 570 (EIA-232 only), Sync 570i (EIA-232/V.35), Sync 570i UIB (PCI boards), Syncport, Sync 2000.

- Sync 2000 single port EIA-530/EIA-422 DB-25 cable - Part #77000425
- Sync 570i UIB single port EIA-530/EIA-422 DB-25 cable - Part #76000369
- Sync 570i 2 port EIA-530/EIA-422 DB-25 - - Part #62500039
- Sync 570i 4 port cable (one port EIA-530/EIA-422) - Part #62500048

DB-25	Direction	Signal
1	↔	CGND
2	→	TxD+
3	←	RxD+
4	→	RTS+
5	←	CTS+
6	←	DCE Ready +
7	↔	SG
8	←	Received Line Signal Indicator +
9	←	RxClk +
10	←	Received Line Signal Indicator -
11	→	TxClk External +
12	←	TxClk Internal -
13	←	CTS-
14	→	TxD-
15	←	TxClk Internal +
16	←	RxD-
17	←	RxClk-
19	→	RTS-
20	→	DTE Ready +
22	←	DCE Ready +
23	→	DTE Ready -
24	→	TxClk External -
Shell	↔	GND

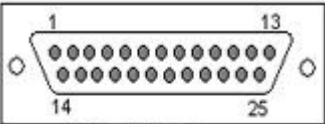

Male DB-25

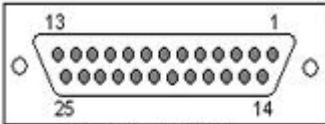

Female DB-25

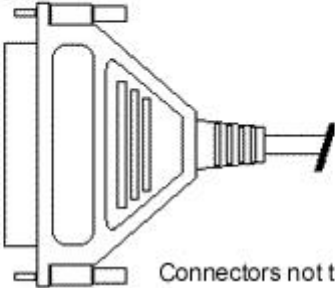

Connectors not to scale

# Sync 2000 Single Port V.36/EIA-449 Pinout

## V.36/EIA-449 Pinout

V.36/EIA-449 Boards with DB-37 cable assemblies (see part numbers for cables below)

Sync 2000 single port V.36/EIA-449 DB-37 cable - Part #77000440

DB-37	Direction	Signal
1	↔	Shield
2	→	Signal Rate Indicator
4	←	Received Data +
5	←	Send Timing +
6	→	Send Data +
7	→	RTS +
8	←	Received Timing +
9	→	CTS +
10	→	Local Loopback
11	←	Data Mode +
12	→	Terminal Ready +
13	→	Receiver Ready +
14	→	Remote Loopback
15	←	Incoming Call
16	←	Select Frequency
17	→	Terminal Timing +
18	←	Test Mode
19	↔	SG
20	↔	Receive Common
22	→	Send Data -
23	←	Send Timing -
24	→	Receive Data -
25	→	RTS-
26	←	Receive Timing -
27	←	CTS-
28	→	Terminal In Service
29	←	Data Mode -

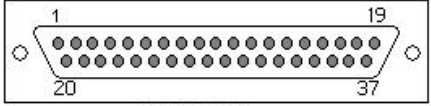

DB-37 Male

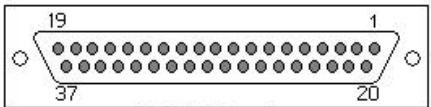

DB-37 Female

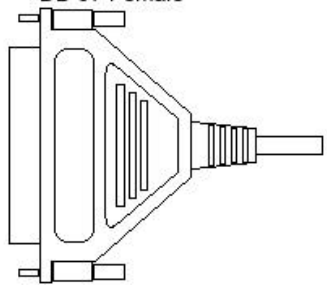

30	➔	Terminal Ready -	
31	➔	Receiver Ready -	
32	➔	Select Standby	
33	➜	Signal Quality	
34	➔	New Signal	
35	➔	Terminal Timing -	
36	➜	Standby Indicator	
37	↔	Send Common	
Shell	↔	GND	

# DB-9F to DB-9M Terminal Printer Cable

## Modem Cables

### Terminal/Printer Cables, DB-9 to DB-9

The wiring diagram for a DB-9 pin to DB-9 pin terminal/printer cable is shown in Table 1.

**Table 1: EIA-232 DB-9 to DB-9 terminal/printer cable**

DB-9	Signal	Direction	Signal	To DB-9
2	RxD	←	TxD	3
3	TxD	→	RxD	2
4	DTR	↕	DSR	6
			DCD	1
5	SG	↔	SG	5
6	DSR	↕	RTS	7
1	DCD			
7	RTS	→	CTS	8
8	CTS	←	DTR	4
Shell	GND	↔	GND	Shell

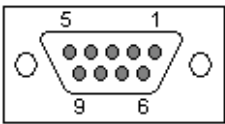

Female

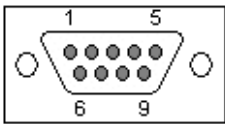

Male DB-9

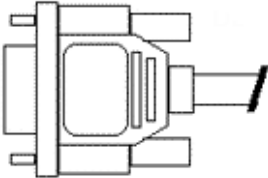
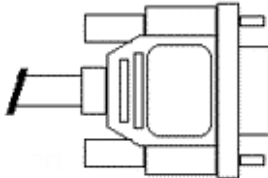
Connectors not to scale

\* Arrows indicate which direction the signal is flowing

#### NOTES:

- Altpin should be turned off when using this cable.
- This cable utilizes the DTR signal of the terminal/printer for hardware flow control (RTS/CTS).



# DB-9F to DB-25M Terminal Printer Cable

## Modem Cables

### Terminal/Printer Cables, DB-9 to DB-25

The wiring diagram for a DB-9 to DB-25 terminal/printer cable is shown in Table 1.

**Table 1: EIA-232 DB-9 to DB-25 terminal/printer cable**

DB-9	Signal	Direction	Signal	To DB-25
2	RxD	←	TxD	2
3	TxD	→	RxD	3
4	DTR	↔	DSR	6
			DCD	8
5	SG	↔	SG	7
6	DSR	↔	RTS	4
1	DCD			
7	RTS	→	CTS	5
8	CTS	←	DTR	20
Shell	GND	↔	GND	Shell

\* Arrows indicate which direction the signal is flowing

#### NOTES:

- Altpin should be turned off when using this cable.
- This cable utilizes the DTR signal of the terminal/printer for hardware flow control (RTS/CTS).

# DB-25F to DB-9M Terminal Printer Cable

## Modem Cables

### Terminal/Printer Cables, DB-25 to DB-9

The wiring diagram for a DB-25 to DB-9 terminal/printer cable is shown in Table 1.

**Table 1: EIA-232 DB-25 to DB-9 terminal/printer cable**

From DB-25	Signal	Direction	Signal	To DB-9
6	DSR	↔	RTS	7
8	DCD			
3	RxD	←	TxD	3
2	TxD	→	RxD	2
20	DTR	→	DSR	6
7	SG	↔	SG	5
4	RTS	→	CTS	8
5	CTS	←	DTR	4
Shell	GND	↔	GND	Shell



Female DB-25

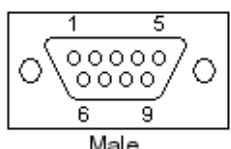

Male

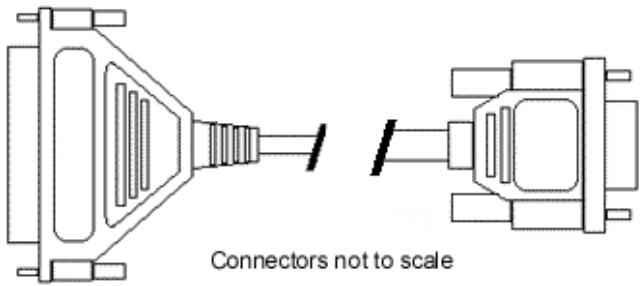

Connectors not to scale

\*Arrows indicate which direction the signal is flowing

**NOTES:**

- AltPin should be turned off when using this cable.
- This cable utilizes the DTR signal of the terminal/printer for hardware flow control (RTS/CTS).

# DB-25F to DB-25M Terminal Printer Cable

## Modem Cables

### Terminal/Printer Cables, DB-25 to DB-25

The wiring diagram for a DB-25 to DB-25 terminal/printer cable is shown in Table 1.

**Table 1: EIA-232 DB-25 to DB-25 terminal/printer cable**

From DB-25	Signal	Direction	Signal	To DB-25
6	DSR	↔	RTS	4
8	DCD	↔		
3	RxD	←	TxD	2
2	TxD	→	RxD	3
20	DTR	↔	DSR	6
			DCD	8
7	SG	↔	SG	7
4	RTS	→	CTS	5
5	CTS	←	DTR	20
Shell	GND	↔	GND	Shell

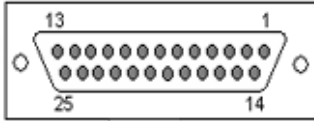
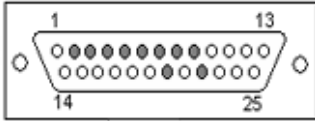
Female DB-25                      Male DB-25

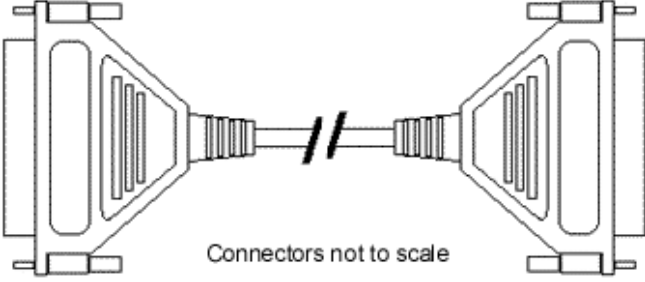

Connectors not to scale

\* Arrows indicate which direction the signal is flowing

#### NOTES:

- Altpin should be turned off when using this cable.
- This cable utilizes the DTR signal of the terminal/printer for hardware flow control (RTS/CTS).
- Okidata printers may use SSD (pin 11) instead of DTR (pin 20) on Term/Prn DB25 side of above diagram. If this is the case, the printer should be set to SSD+.

# SCSI Terminal Server DB-25M to DB-9M Terminal Printer Cable

## Cables

### Terminal/Printer Cables, DB-25 to DB-9

EIA-232 Boards which require DB-25 Male Cables Connectors - SCSI Terminal Server ST1002, SCSI Terminal Server ST1008, SCSI Terminal Server ST1016, SCSI Terminal Server ST1600

The wiring diagram for a DB-25 to DB-9 terminal/printer cable is shown in Table 1.

**Table 1: EIA-232 DB-25 to DB-9 terminal/printer cable**

From DB-25	Signal	Direction	Signal	To DB-9
6	DSR	↔	RTS	7
8	DCD	↔		
3	RxD	←	TxD	3
2	TxD	→	RxD	2
20	DTR	→	DSR	6
7	SG	↔	SG	5
4	RTS	→	CTS	8
5	CTS	←	DTR	4
Shell	GND	↔	GND	Shell

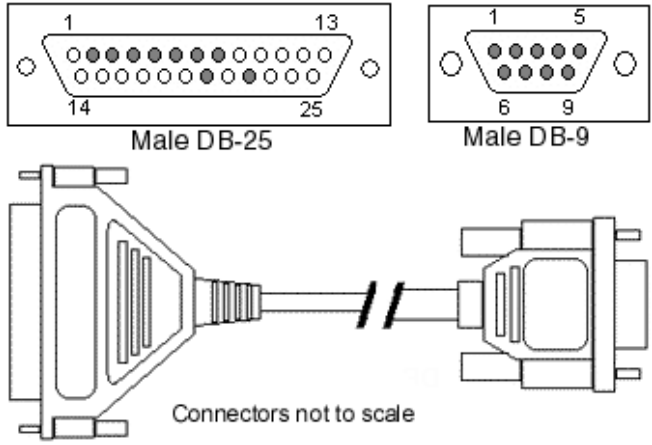

\* Arrows indicate which direction the signal is flowing

# SCSI Terminal Server DB-25M to DB-25M Terminal Printer Cable

## Modem Cables

### Terminal/Printer Cables, DB-25 to DB-25

EIA-232 Boards which require DB-25 Male Cables Assemblies (see part numbers below) - SCSI Terminal Server ST1002, SCSI Terminal Server ST1008, SCSI Terminal Server ST1016, SCSI Terminal Server ST1600

The wiring diagram for a DB-25 to DB-25 terminal/printer cable is shown in Table 1.

Table 1: EIA-232 DB-25 to DB-25 terminal/printer cable

From Port DB-25	Signal	Direction	Signal	To Term/Prn DB-25
6	DSR	↔	RTS	4
8	DCD			
3	RxD	←	TxD	2
2	TxD	→	RxD	3
20	DTR	↔	DSR	6
			DCD	8
7	SG	↔	SG	7
4	RTS	→	CTS	5
5	CTS	←	DTR	20
Shell	GND	↔	GND	Shell

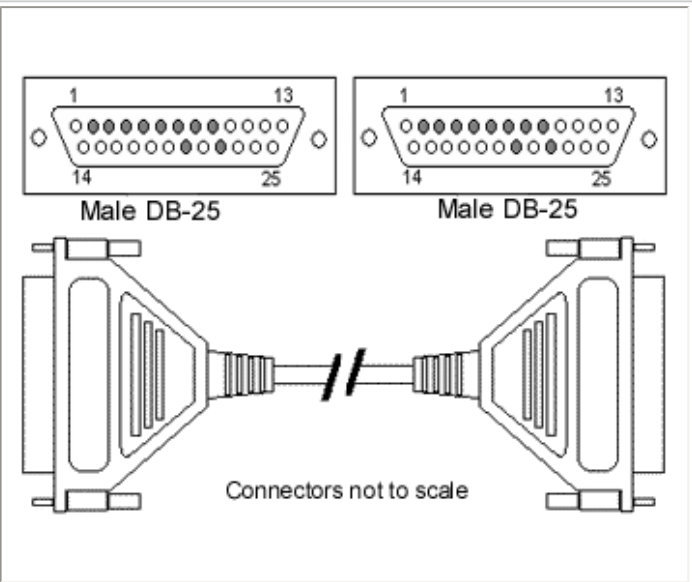

\* Arrows indicate which direction the signal is flowing

# RJ-11 6 Pin/4-Wire to DB-9M Terminal Printer Cable

## Modem Cables

### Terminal/Printer Cables, RJ-11 6-pin/4-wire to DB-9

The wiring diagram for an RJ-11 6-pin/4-wire to DB-9 terminal/printer cable is shown in Table 1.

**Table 1: EIA-232 RJ-11 6-pin/4-wire to DB-9 terminal/printer cable**

From RJ-11	Signal	Direction	Signal	To DB-9
4	RxD	←	TxD	3
3	TxD	→	RxD	2
5	SG	↔	SG	5
2	GND	↔	GND	Shell

FRONT:



RJ-11 6-pin

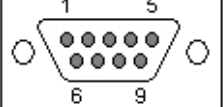

Male DB-9

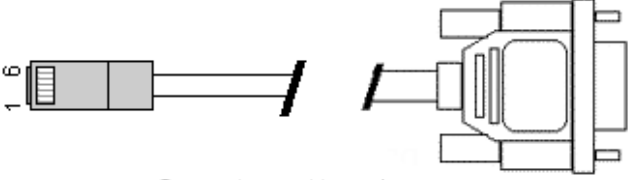

Connectors not to scale

\* Arrows indicate which direction the signal is flowing

#### NOTES:

- This cable can only be used with Software Flow Control (Xon/Xoff).
- Some Unix operating systems require carrier to be present. If this is the case, the `forcedcd` parameter will need to be turned on for this port at the host.

# RJ-11 6 Pin/4-Wire to DB-25M Terminal Printer Cable

## Modem Cables

### Terminal/Printer Cables, RJ-11 6-pin/4-wire to DB-25

The wiring diagram for an RJ-11 6-pin/4-wire to DB-25 terminal/printer cable is shown in Table 1.

**Table 1: EIA-232 RJ-11 6-pin/4-wire to DB-25 terminal/printer cable**

From RJ-11	Signal	Direction	Signal	To DB-25
4	RxD	←	TxD	2
3	TxD	→	RxD	3
5	SG	↔	SG	7
2	GND	↔	GND	Shell

\* Arrows indicate which direction the signal is flowing

#### NOTES:

- This cable can only be used with Software Flow Control (Xon/Xoff).
- Some Unix operating systems require carrier to be present. If this is the case, the `forcedcd` parameter will need to be turned on for this port at the host.

# RJ-11 6 Pin to DB-9F Terminal Printer Cable

## Cables

### EIA-232 PC Terminal Emulator Cables, RJ-11 6-pin to DB-9

The wiring diagram for an RJ-11 6-pin to DB-9 PC terminal emulator cable is shown in Table 1.

**Table 1: EIA-232 RJ-11 6-pin to DB-9 PC terminal emulator cable**

From RJ-11	Signal	Direction	Signal	To DB-9
4	RxD	←	TxD	3
3	TxD	→	RxD	2
5	SG	↔	SG	5
1	RTS	→	CTS	8
6	CTS	←	RTS	7
2	GND	↔	GND	Shell

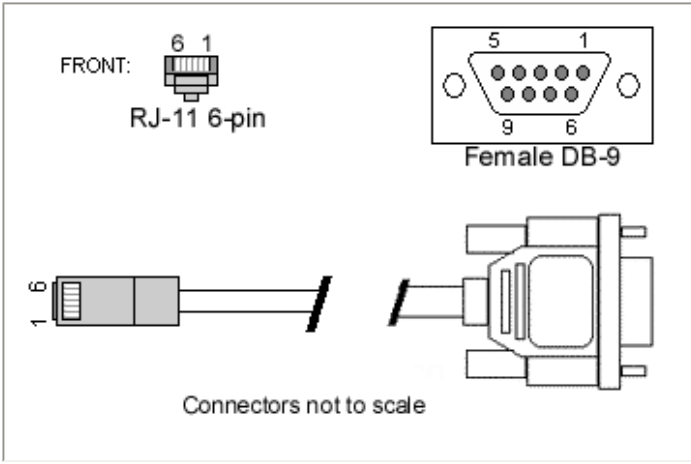

\* Arrows indicate which direction the signal is flowing

#### NOTES:

- This cable utilizes the RTS signal of the PC terminal emulator for hardware flow control (RTS/CTS).
- Some Unix operating systems require carrier to be present. If this is the case, the `forcedcd` parameter will need to be turned on for this port at the host.



# RJ-11 6 Pin to DB-25M Terminal Printer Cable

## Cables

### Terminal/Printer Cables, RJ-11 6-pin to DB-25

The wiring diagram for an RJ-11 6-pin to DB-25 terminal/printer cable is shown in Table 1.

**Table 1: EIA-232 RJ-11 6-pin to DB-25 terminal/printer cable**

From RJ-11	Signal	Direction	Signal	To DB-25
4	RxD	←	TxD	2
3	TxD	→	RxD	3
5	SG	↔	SG	7
1	RTS	→	CTS	5
6	CTS	←	DTR	20
2	GND	↔	GND	Shell

\* Arrows indicate which direction the signal is flowing

#### NOTES:

- This cable utilizes the DTR signal of the terminal/printer for hardware flow control (RTS/CTS).
- Okidata printers may use SSD (pin 11) instead of DTR (pin 20) on DB25 side in above diagram. If this is the case, the printer should be set to SSD+.
- Some Unix operating systems require carrier to be present. If this is the case, the `forcedcd` parameter will need to be turned on for this port at the host.

# RJ-45 4-Wire to DB-9M Terminal Printer Cable Software Flow Control Only

## Cables

# EIA-232 Terminal/Printer Cables, RJ-45 8-pin/4-wire to DB-9 9 Software Flow Control Only

The wiring diagram for an RJ-45 8-pin to DB-9 terminal/printer cable using only 4 wires is shown in Table 1.

**Table 1: EIA-232 RJ-45 8-pin to DB-9 terminal/printer cable using only 4 wires**

From RJ-45	Signal	Direction	Signal	To DB-9
3	GND	↔	GND	Shell
4	TxD	→	RxD	2
5	RxD	←	TxD	3
6	SG	↔	SG	5
1	DCD	←	RTS	7

FRONT: 8 1  
RJ-45 8-Pin

1 5  
6 9  
Male DB-9

Connectors not to scale

\* Arrows indicate which direction the signal is flowing

### NOTES:

- This cable can only be used with Software Flow Control (Xon/Xoff).
- Some Unix operating systems require carrier to be present. If this is the case, altpin must be turned on and the DCD-RTS wire added (in some cases it may be possible to wire DCD-RTS as the fourth wire instead of GND).

## RJ-45 4-Wire to DB-25M Terminal Printer Cable

### Cables

## EIA-232 Terminal/Printer Cables, RJ-45 8-pin/4-wire to DB-25

The wiring diagram for an RJ-45 8-pin to DB-25 terminal/printer cable using only 4 wires is shown in Table 1.

**Table 1: EIA-232 RJ-45 8-pin to DB-25 terminal/printer cable using only 4 wires**

From RJ-45	Signal	Direction	Signal	To DB-25
3	GND	↔	GND	Shell
4	TxD	→	RxD	3
5	RxD	←	TxD	2
6	SG	↔	SG	7
1	DCD	←	RTS	4

\* Arrows indicate which direction the signal is flowing

### NOTES:

- This cable can only be used with Software Flow Control (Xon/Xoff).
- Some Unix operating systems require carrier to be present. If this is the case, altpin must be turned on and the DCD-RTS wire added (in some cases it may be possible to wire DCD-RTS as the fourth wire instead of GND).

## RJ-45 (Altpin On) to DB-9M Terminal Printer Cable

# Terminal/Printer Cables, Altpin RJ-45 8-pin to DB-9

The wiring diagram for an altpin RJ-45 8-pin to DB-9 terminal/printer cable is shown in Table 1.

**Table 1: EIA-232 altpin RJ-45 8-pin to DB-9 terminal/printer cable**

From RJ-45	Signal	Direction	Signal	To DB-9
3	GND	↔	GND	Shell
4	TxD	→	RxD	2
5	RxD	←	TxD	3
6	SG	↔	SG	5
7	CTS	←	DTR	4
1	DCD	←	RTS	7
2	RTS	→	CTS	8
8	DTR	→	DSR	6

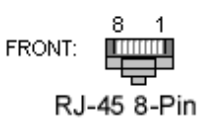

FRONT:  
RJ-45 8-Pin

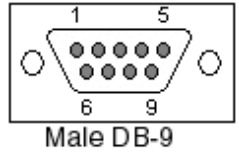

Male DB-9

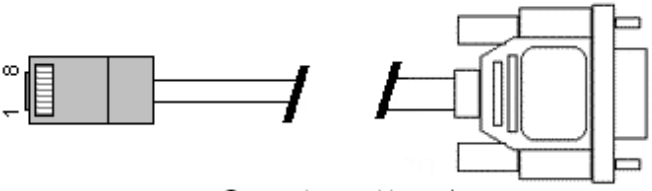

Connectors not to scale

\* Arrows indicate which direction the signal is flowing

### NOTES:

- Altpin should be turned on when using this cable so that DTR will drive DCD (standard usage).
- If altpin is turned off, the hardware signal on RJ45 pin 1 becomes DSR instead of DCD. This alternative can be used if DCD is not required, and DSR is needed instead.
- This cable utilizes the DTR signal of the terminal/printer for hardware flow control (RTS/CTS).
- EIA-232 cables cannot exceed 2500pF.

# RJ-45 to DB-25M Terminal Printer Cable

## Terminal/Printer Cables

### EIA-232 Terminal/Printer Cables, Altpin RJ-45 8-pin to DB-25

The wiring diagram for an altpin RJ-45 8-pin to DB-25 terminal/printer cable is shown in Table 1.

**Table 1: EIA-232 Altpin RJ-45 8-pin to DB-25 terminal/printer cable**

From RJ-45	Signal	Direction	Signal	To DB-25
1	DSR	←	RTS	4
5	RxD	←	TxD	2
4	TxD	→	RxD	3
8	DTR	↔	DSR	6
			DCD	8
6	SG	↔	SG	7
2	RTS	→	CTS	5
7	CTS	←	DTR	20
3	GND	↔	GND	Shell

\* Arrows indicate which direction the signal is flowing

#### NOTES:

- Altpin should be turned on when using this cable so that DTR will drive DCD (standard usage).
- If altpin is turned off, the hardware signal on RJ45 pin 1 becomes DSR instead of DCD. This alternative can be used if DCD is not required, and DSR is needed instead.
- This cable utilizes the DTR signal of the terminal/printer for hardware flow control (RTS/CTS).
- Okidata printers may use SSD (pin 11) instead of DTR (pin 20) on DB25 side of above diagram. If this is the case, the printer should be set to SSD+.

# RJ-45 to DB-9M Terminal Printer Cable

## Cables

### Terminal/Printer Cables, RJ-45 8-pin to DB-9

The wiring diagram for an RJ-45 8-pin to DB-9 terminal/printer cable is shown in Table 1.

**Table 1: EIA-232 altpin RJ-45 8-pin to DB-9 terminal/printer cable**

From RJ-45	Signal	Direction	Signal	To DB-9
3	GND	↔	GND	Shell
4	TxD	→	RxD	2
5	RxD	←	TxD	3
6	SG	↔	SG	5
7	CTS	←	DTR	4
1	DSR	←	RTS	7
2	RTS	→	CTS	8
8	DTR	→	DSR	6



FRONT:  
RJ-45 8-Pin

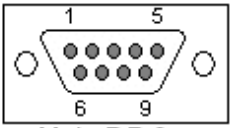

Male DB-9

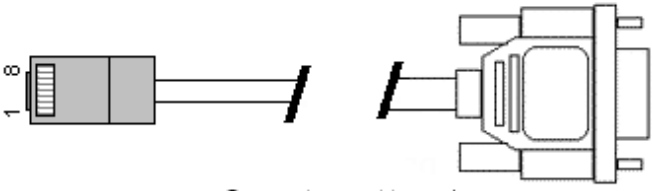

Connectors not to scale

\* Arrows indicate which direction the signal is flowing

#### NOTES:

- Altpin should be turned off when using this cable so that pin 1 becomes DSR instead of DCD. This alternative can be used if DCD is not required, and DSR is needed instead.
- This cable utilizes the DTR signal of the terminal/printer for hardware flow control (RTS/CTS).

# RJ-45 10 Pin to DB-9M Terminal Printer Cable

## Cables

### EIA-232 Terminal/Printer Cables, RJ-45 10-pin to DB-9

Table 1: EIA-232 RJ-45 10-pin to DB-9 terminal/printer cable

From RJ-45	Signal	Direction	Signal	To DB-9
10	DCD	↔	RTS	7
2	DSR			
6	RxD	←	TxD	3
5	TxD	→	RxD	2
9	DTR	↔	DSR	6
			DCD	1
7	SG	↔	SG	5
3	RTS	→	CTS	8
8	CTS	←	DTR	4
4	GND	↔	GND	Shell

FRONT:



RJ-45 10-Pin

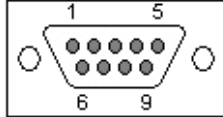

Male DB-9

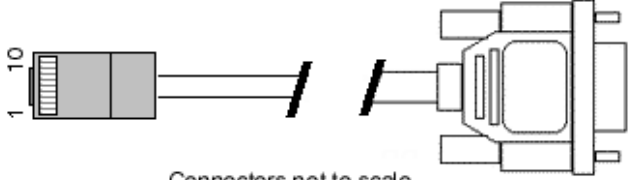

Connectors not to scale

\* Arrows indicate which direction the signal is flowing

#### NOTES:

- Altpin should be turned off when using this cable.
- This cable utilizes the DTR signal of the terminal/printer for hardware flow control (RTS/CTS).

# RJ-45 10 Pin to DB-25M Terminal Printer Cable

## Cables

### EIA-232 Terminal/Printer Cables, RJ-45 10-pin to DB-25

The wiring diagram for an RJ-45 10-pin to DB-25 terminal/printer cable is shown in Table 1.

**Table 1: EIA-232 RJ-45 10-pin to DB-25 terminal/printer cable**

From RJ-45	Signal	Direction	Signal	To DB-25
10	DCD	↔	RTS	4
2	DSR			
6	RxD	←	TxD	2
5	TxD	→	RxD	3
9	DTR	↔	DSR	6
			DCD	8
7	SG	↔	SG	7
3	RTS	→	CTS	5
8	CTS	←	DTR	20
4	GND	↔	GND	Shell

\* Arrows indicate which direction the signal is flowing

This cable can also be purchased from Digi (see part number below).

- 4' RJ-45 10-pin to DB-25 - Part #76000238

#### NOTES:

- Altpin should be turned off when using this cable.
- This cable utilizes the DTR signal of the terminal/printer for hardware flow control (RTS/CTS).
- Okidata printers may use SSD (pin 11) instead of DTR (pin 20) on DB25 side of above diagram. If this is the case, the printer should be set to SSD+.